

# Ohio University Interior Architecture

Matthew Ziff, M.Arch, Associate Professor

## Codes Check 1

**This reference document provides excerpts from building codes that state what is required, by law, for interior environments.**

1. **Building-** per FBC-B

I. **Construction Type-** per Section 602

*602.1 General. Buildings and structures erected or to be erected, altered or extended in height or area shall be classified in one of the five construction types defined in Sections 602.2 through 602.5. The building elements shall have a fire-resistance rating not less than that specified in Table 601 and exterior walls shall have a fire-resistance rating not less than that specified in Table 602.*

*602.1.1 Minimum requirements. A building or portion thereof shall not be required to conform to the details of a type of construction higher than that type, which meets the minimum requirements based on occupancy even though certain features of such a building actually conform to a higher type of construction.*

*602.2 Types I and II. Type I and II construction are those types of construction in which the building elements listed in Table 601 are of noncombustible materials, except as permitted in Section 603 and elsewhere in this code.*

*602.3 Type III. Type III construction is that type of construction in which the exterior walls are of noncombustible materials and the interior building elements are of any material permitted by this code. Fire-retardant-treated wood framing complying with Section 2303.2 shall be permitted within exterior wall assemblies of a 2-hour rating or less.*

*602.4 Type IV. Type IV construction (Heavy Timber, HT) is that type of construction in which the exterior walls are of noncombustible materials and the interior building elements are of solid or laminated wood without concealed spaces. The details of Type IV construction shall comply with the provisions of this section. Fire-retardant-treated wood framing complying with Section*

*2303.2 shall be permitted within exterior wall assemblies with a 2-hour rating or less. Minimum solid sawn nominal dimensions are required for structures built using Type IV construction (HT). For glued-laminated members the equivalent net finished width and depths corresponding to the minimum nominal width and depths of solid sawn lumber are required as specified in Table 602.4.*

*602.4.1 Columns. Wood columns shall be sawn or glued laminated and shall not be less than 8 inches (203 mm), nominal, in any dimension where supporting floor loads and not less than 6 inches (152 mm) nominal in width and not less than 8 inches (203 mm) nominal in depth where supporting roof and ceiling loads only. Columns shall be continuous or superimposed and connected in an approved manner.*

*602.4.2 Floor framing. Wood beams and girders shall be of sawn or glued-laminated timber and shall be not less than 6 inches (152 mm) nominal in width and not less than 10 inches (254 mm) nominal in depth. Framed sawn or glued-laminated timber arches, which spring from the floor line and support floor loads, shall be not less than 8 inches (203 mm) nominal in any dimension. Framed timber trusses supporting floor loads shall have members of not less than 8 inches (203 mm) nominal in any dimension.*

*602.4.3 Roof framing. Wood-frame or glued-laminated arches for roof construction, which spring from the floor line or from grade and do not support floor loads, shall have members not less than 6 inches (152 mm) nominal in width and have less than 8 inches (203 mm) nominal in depth for the lower half of the height and not less than 6 inches (152 mm) nominal in depth for the upper half. Framed or glued-laminated arches for roof construction that spring from the top of walls or wall abutments, framed timber trusses and other roof framing, which do not support floor loads, shall have members not less than 4 inches (102 mm) nominal in width and not less than 6 inches (152 mm) nominal in depth. Spaced members shall be permitted to be composed of two or more pieces not less than 3 inches (76 mm) nominal in thickness where blocked solidly*

*throughout their intervening spaces or where spaces are tightly closed by a continuous wood cover plate of not less than 2 inches (51 mm) nominal in thickness secured to the underside of the members. Splice plates shall be not less than 3 inches (76 mm) nominal in thickness. Where protected by approved automatic sprinklers under the roof deck, framing members shall be not less than 3 inches (76 mm) nominal in width.*

*602.4.4 Floors. Floors shall be without concealed spaces. Wood floors shall be of sawn or glued-laminated planks, splined or tongue-and-groove, of not less than 3 inches (76 mm) nominal in thickness covered with 1-inch (25 mm) nominal dimension tongue-and-groove flooring, laid crosswise or diagonally, or 0.5-inch (12.7 mm) particleboard or planks not less than 4 inches (102 mm) nominal in width set on edge close together and well spiked and covered with 1-inch (25 mm) nominal dimension flooring or  $1\frac{5}{32}$ -inch (12 mm) wood structural panel or 0.5-inch (12.7 mm) particleboard. The lumber shall be laid so that no continuous line of joints will occur except at points of support. Floors shall not extend closer than 0.5 inch (12.7 mm) to walls. Such 0.5-inch (12.7 mm) space shall be covered by a molding fastened to the wall and so arranged that it will not obstruct the swelling or shrinkage movements of the floor. Corbeling of masonry walls under the floor shall be permitted to be used in place of molding.*

*602.4.5 Roofs. Roofs shall be without concealed spaces and wood roof decks shall be sawn or glued laminated, splined or tongue-and-groove plank, not less than 2 inches (51 mm) nominal in thickness,  $1\frac{1}{8}$ -inch-thick (32 mm) wood structural panel (exterior glue), or of planks not less than 3 inches (76 mm) nominal in width, set on edge close together and laid as required for floors. Other types of decking shall be permitted to be used if providing equivalent fire resistance and structural properties.*

*602.4.6 Partitions. Partitions shall be of solid wood construction formed by not less than two layers of 1-inch (25 mm) matched boards or laminated*

construction 4 inches (102 mm) thick, or of 1-hour fire-resistance-rated construction.

602.4.7 Exterior structural members. Where a horizontal separation of 20 feet (6096 mm) or more is provided, wood columns and arches conforming to heavy timber sizes shall be permitted to be used externally.

602.5 Type V. Type V construction is that type of construction in which the structural elements, exterior walls and interior walls are of any materials permitted by this code.

II. **Number of Stories-** per Table 503

III. **Square Footage-** per Table 503

*Height limitations shown as stories and feet above grade plane. Area limitations as determined by the definition of "Area, building," per story*

GROUP	HGT(feet) HGT(S)	TYPE OF CONSTRUCTION								
		TYPE I		TYPE II		TYPE III		TYPE IV	TYPE V	
		A	B	A	B	A	B	HT	A	B
		UL	160	65	55	65	55	65	50	40
A-1	S	UL	5	3	2	3	2	3	2	1
	A	UL	UL	15,500	8,500	14,000	8,500	15,000	11,500	5,500
A-2	S	UL	11	3	2	3	2	3	2	1
	A	UL	UL	15,500	9,500	14,000	9,500	15,000	11,500	6,000
A-3	S	UL	11	3	2	3	2	3	2	1
	A	UL	UL	15,500	9,500	14,000	9,500	15,000	11,500	6,000
A-4	S	UL	11	3	2	3	2	3	2	1
	A	UL	UL	15,500	9,500	14,000	9,500	15,000	11,500	6,000
A-5	S	UL	UL	UL	UL	UL	UL	UL	UL	UL
	A	UL	UL	UL	UL	UL	UL	UL	UL	UL
B	S	UL	11	5	4	5	4	5	3	2
	A	UL	UL	37,500	23,000	28,500	19,000	36,000	18,000	9,000
E/D	S	UL	5	3	2	3	2	3	1	1
	A	UL	UL	26,500	14,500	23,500	14,500	25,500	18,500	9,500
F-1	S	UL	11	4	2	3	2	4	2	1
	A	UL	UL	25,000	15,500	19,000	12,000	33,500	14,000	8,500
F-2/F-3	S	UL	11	5	3	4	3	5	3	2
	A	UL	UL	37,500	23,000	28,500	18,000	50,500	21,000	13,000
H-1	S	1	1	1	1	1	1	1	1	NP
	A	21,000	16,500	11,000	7,000	9,500	7,000	10,500	7,500	NP
H-2 <sup>d</sup>	S	UL	3	2	1	2	1	2	1	1
	A	21,000	16,500	11,000	7,000	9,500	7,000	10,500	7,500	3,000
H-3 <sup>d</sup>	S	UL	6	4	2	4	2	4	2	1
	A	UL	60,000	26,500	14,000	17,500	13,000	25,500	10,000	5,000
H-4	S	UL	7	5	3	5	3	5	3	2
	A	UL	UL	37,500	17,500	28,500	17,500	36,000	18,000	6,500
H-5	S	4	4	3	3	3	3	3	3	2
	A	UL	UL	37,500	23,000	28,500	19,000	36,000	18,000	9,000
I-1	S	UL	9	4	3	4	3	4	3	2
	A	UL	55,000	19,000	10,000	16,500	10,000	18,000	10,500	4,500
I-2	S	UL	4	2	1	1	NP	1	1	NP
	A	UL	UL	15,000	11,000	12,000	NP	12,000	9,500	NP
I-3	S	UL	4	2	1	2	1	2	2	1
	A	UL	UL	15,000	10,000	10,500	7,500	12,000	7,500	5,000

M	S A	UL UL	11 UL	4 21,500	4 12,500	4 18,500	4 12,500	4 20,500	3 14,000	1 9,000
R-1	S A	UL UL	11 UL	4 24,000	4 16,000	4 24,000	4 16,000	4 20,500	3 12,000	2 7,000
R-2	S A	UL UL	11 UL	4 24,000	4 16,000	4 24,000	4 16,000	4 20,500	3 12,000	2 7,000
R-3	S A	UL UL	11 UL	4 UL	4 UL	4 UL	4 UL	4 UL	3 UL	3 UL
R-4	S A	UL UL	11 UL	4 24,000	4 16,000	4 24,000	4 16,000	4 20,500	3 12,000	2 7,000
S-1	S A	UL UL	11 48,000	4 26,000	3 17,500	3 26,000	3 17,500	4 25,500	3 14,000	1 9,000
S-2 <sup>b,c</sup>	S A	UL UL	11 79,000	5 39,000	4 26,000	4 39,000	4 26,000	5 38,500	4 21,000	2 13,500
U <sup>c</sup>	S A	UL UL	5 35,500	4 19,000	2 8,500	3 14,000	2 8,500	4 18,000	2 9,000	1 5,500

For SI: 1 foot = 304.8 mm, 1 square foot = 0.0929 m<sup>2</sup>.

UL = Unlimited, NP = Not permitted.

a. See the following sections for general exceptions to Table 503:

1. Section 504.2, Allowable height increase due to automatic sprinkler system installation.
2. Section 506.2, Allowable area increase due to street frontage.
3. Section 506.3, Allowable area increase due to automatic sprinkler system installation.
4. Section 507, Unlimited area buildings.

b. For open parking structures, see Section 406.3.

c. For private garages, see Section 406.1.

d. See Section 415.5 for limitations.

*Exception: The height of one-story aircraft hangars, aircraft paint hangars and buildings used for the manufacturing of aircraft shall not be limited if the building is provided with an automatic fire-extinguishing system in accordance with Chapter 9 and is entirely surrounded by public ways or yards not less in width than one and one-half times the height of the building.*

#### IV. **Area Modification-** per section 506

506.1 General. The areas limited by Table 503 shall be permitted to be increased due to frontage ( $I_f$ ) and automatic sprinkler system protection ( $I_s$ ) in accordance with the following:

$$A_a = \{ A_t + [A_t \times I_f] + [A_t \times I_s] \}$$

(Equation 5-1)

where:

$A_a$  = Allowable area per story (square feet).

$A_t$  = Tabular area per story in accordance with Table 503 (square feet).

$I_f$  = Area increase factor due to frontage as calculated in accordance with Section 506.2.

$I_s$  = Area increase factor due to sprinkler protection as calculated in accordance with Section 506.3.

506.1.1 Basements. A single basement that is not a story above grade plane need not be included in the total allowable area, provided such basement does not exceed the area permitted for a building with no more than one story above grade plane.

506.2 Frontage increase. Every building shall adjoin or have access to a public way to receive an area increase for frontage. Where a building has more than 25 percent of its perimeter on a public way or open space having a minimum width of 20 feet (6096 mm), the frontage increase shall be determined in accordance with the following:

$$I_f = [F / P - 0.25] W / 30$$

(Equation 5-2)

where:

$I_f$  = Area increase due to frontage.

$F$  = Building perimeter that fronts on a public way or open space having 20 feet (6096 mm) open minimum width (feet).

$P$  = Perimeter of entire building (feet).

$W$  = Width of public way or open space (feet) in accordance with Section 506.2.1.

506.2.1 Width limits. "W" must be at least 20 feet (6096 mm). Where the value of  $W$  varies along the perimeter of the building, the calculation performed in accordance with Equation 5-2 shall be based on the weighted average of each portion of exterior wall and open space where the value of  $W$  is greater than or equal to 20 feet (6096 mm). Where  $W$  exceeds 30 feet (9144 mm), a value of 30 feet (9144 mm) shall be used in calculating the weighted average, regardless of the actual width of the open space.

Exception: The quantity of  $W$  divided by 30 shall be permitted to be a maximum of 2 when the building meets all requirements of Section 507 except for compliance with the 60-foot (18 288 mm) public way or yard requirement, as applicable.

*506.2.2 Open space limits. Such open space shall be either on the same lot or dedicated for public use and shall be accessed from a street or approved fire lane.*

*506.3 Automatic sprinkler system increase. Where a building is equipped throughout with an approved automatic sprinkler system in accordance with Section 903.3.1.1, the area limitation in Table 503 is permitted to be increased by an additional 200 percent ( $I_s = 2$ ) for buildings with more than one story above grade plane and an additional 300 percent ( $I_s = 3$ ) for buildings with no more than one story above grade plane. These increases are permitted in addition to the height and story increases in accordance with Section 504.2. Exception: The area limitation increases shall not be permitted for the following conditions:*

*1. The automatic sprinkler system increase shall not apply to buildings with an occupancy in Use Group H-1.*

*2. The automatic sprinkler system increase shall not apply to the floor area of an occupancy in Use Group H-2 or H-3. For mixed-use buildings containing such occupancies, the allowable area shall be calculated in accordance with Section 508.3.3.2, with the sprinkler increase applicable only to the portions of the building not classified as Use Group H-2 or H-3.*

*3. Fire-resistance rating substitution in accordance with Table 601, Note h.*

*506.4 Area determination. The maximum area of a building with more than one story above grade plane shall be determined by multiplying the allowable area of the first story ( $A_a$ ), as determined in Section 506.1, by the number of stories above grade plane as listed below:*

*1. For buildings with two stories above grade plane, multiply by 2;*

*2. For buildings with three or more stories above grade plane, multiply by 3; and*

*3. No story shall exceed the allowable area per story ( $A_a$ ), as determined in Section 506.1, for the occupancies on that story.*

*Exceptions:*

1. *Unlimited area buildings in accordance with Section 507.*
  2. *The maximum area of a building equipped throughout with an automatic sprinkler system in accordance with Section 903.3.1.2 shall be determined by multiplying the allowable area per story ( $A_a$ ), as determined in Section 506.1, by the number of stories above grade plane.*
- 506.4.1 Mixed occupancies. In buildings with mixed occupancies, the allowable area per story ( $A_a$ ) shall be based on the most restrictive provisions for each occupancy when the mixed occupancies are treated according to Section 508.3.2. When the occupancies are treated according to Section 508.3.3 as separated occupancies, the maximum total building area shall be such that the sum of the ratios for each such area on all floors as calculated according to Section 508.3.3.2 shall not exceed 2 for two-story buildings and 3 for buildings three stories or higher.*

**2. Occupancy-** per FBC-B

**I. Occupancy Type-** per section 302

*302.1 General. Structures or portions of structures shall be classified with respect to occupancy in one or more of the groups listed below. Structures with multiple uses shall comply with Section 302.3. Where a structure is proposed for a purpose that is not specifically provided for in this code, such structure shall be classified in the group that the occupancy most nearly resembles, according to the fire safety and relative hazard involved.*

1. *Assembly (see Section 303): Groups A-1, A-2, A-3, A-4 and A-5*
2. *Business (see Section 304): Group B*
3. *Educational (see Section 305): Group E*
4. *Factory and Industrial (see Section 306): Groups F-1, F-2 and F-3.*
5. *High Hazard (see Section 307): Groups H-1, H-2, H-3, H-4 and H-5*
6. *Institutional (see Section 308): Groups I-1, I-2 and I-3*
7. *Mercantile (see Section 309): Group M*
8. *Residential (see Section 310): Groups R-1, R-2, R-3 as applicable in Section 101.2, and R-4*



9. Storage (see Section 311): Groups S-1 and S-2

10. Utility and Miscellaneous (see Section 312):

Group U

11. Day care (see Section 313): Group D

II. **Occupancy Load-** per Table 1004.1.1

FUNCTION OF SPACE	FLOOR AREA IN SQ FT PER OCCUPANT
Accessory storage areas, mechanical equipment room	300 gross
Agricultural building	300 gross
Aircraft hangars	500 gross
Airport terminal	
Baggage claim	20 gross
Baggage handling	300 gross
Concourse	100 gross
Waiting areas	15 gross
Assembly	
Gaming floors (keno, slots, etc.)	11 gross
Assembly with fixed seats	See Section 1004.7
Assembly without fixed seats	
Concentrated (chairs only-not fixed)	7 net
Standing space	5 net
Unconcentrated (tables and chairs)	15 net
Bowling centers, allow 5 persons for each lane including 15 feet of runway, and for additional areas	7 net
Business areas	100 gross
Courtrooms-other than fixed seating areas	40 net
Day care	20net
Dormitories	50 gross
Educational	
Classroom area	
Shops and other vocational room areas	20 net 50 net
Exercise rooms	50 gross
Exercise rooms with equipment	50 gross
Exercise rooms without equipment	15 gross
H-5 Fabrication and manufacturing areas	200 gross
Industrial areas	100 gross
Institutional areas	
Inpatient treatment areas	240 gross
Outpatient areas	100 gross
Sleeping areas	120 gross
Kitchens, commercial	200 gross
Library	
Reading rooms	50 net
Stack area	100 gross
Locker rooms	50 gross

Mercantile	
Areas on other floors	60 gross
Basement and grade floor areas	30 gross
Multiple street floors - each (Note 1)	40 gross
Storage, stock, shipping areas	300 gross
Parking garages	200 gross
Residential	200 gross
Skating rinks, swimming pools	
Rink and pool	50 gross
Swimming pool deck	30 gross
Swimming pool water surface	50 gross
Decks	15 gross
Stages and platforms	15 net
Warehouses	500 gross

*For SI: 1 square foot = 0.0929 m<sup>2</sup>.*

1. *For the purpose of determining occupant load in mercantile occupancies where, due to differences in grade of streets on different sides, two or more floors directly accessible from streets exist, each such floor shall be considered a street floor. The occupant load factor shall be one person for each 40 square feet (3.7 m<sup>2</sup>) of gross floor area of sales space.*
2. *For any food court or other assembly use areas located in the mall that are not included as a portion of the gross leasable area of the mall buildings, the occupant load is calculated based on the occupant load factor for that use as specified in Table 1004.1.1. The remaining mall area is not required to be assigned an occupant load.*

### 3. **Life Safety**- per FBC-B

#### I. **Fire Suppression System**- per Section 903

*903.1 General. Automatic sprinkler systems shall comply with this section. [F]*

*903.1.1 Alternative protection. Alternative automatic fire-extinguishing systems complying with Section 904 shall be permitted in lieu of automatic sprinkler protection where recognized by the applicable standard and approved by the fire code official. [F]*

*903.2 Where required. Approved automatic sprinkler systems in new buildings and structures shall be provided in the locations described in this section. [F]*

*Exception: Spaces or areas in telecommunications buildings used exclusively for telecommunications equipment, associated electrical power distribution equipment, batteries and standby engines, provided those spaces or areas are equipped throughout with an*

*automatic fire alarm system and are separated from the remainder of the building by fire barriers consisting of not less than 1-hour fire-resistance-rated walls and 2-hour fire-resistance-rated floor/ceiling assemblies.*

**II. Flame Spread of Finishes- per Table 803.5**

GROUP	SPRINKLERED <sup>1</sup>			NONSPRINKLERED		
	Exit enclosures and exit passageways <sup>a,b</sup>	Corridors	Rooms and enclosed spaces <sup>c</sup>	Exit enclosures and exit passageways <sup>a,b</sup>	Corridors	Rooms and enclosed spaces <sup>c</sup>
A-1 & A-2	B	B	C	A	A <sup>d</sup>	B <sup>e</sup>
A-3 <sup>†</sup> , A-4, A-5	B	B	C	A	A <sup>d</sup>	C
B, D, E, M, R-1, R-4	B	C	C	A	B	C
F	C	C	C	B	C	C
H	B	B	C <sup>g</sup>	A	A	B
I-1	B	C	C	A	B	B
I-2	B	B	B <sup>h,1</sup>	A	A	B
I-3	A	A <sup>l</sup>	C	A	A	B
R-2	C	C	C	B	B	C
R-3	C	C	C	C	C	C
S	C	C	C	B	B	C
U	No restrictions			No restrictions		

*For SI: 1 inch = 25.4 mm, 1 square foot = 0.0929 m<sup>2</sup>.*

*a. Class C interior finish materials shall be permitted for wainscoting or paneling of not more than 1,000 square feet of applied surface area in the grade lobby where applied directly to a noncombustible base or over furring strips applied to a noncombustible base and fireblocked as required by Section 803.4.1.*

*b. In exit enclosures of buildings less than three stories in height of other than Group I-3, Class B interior finish for nonsprinklered buildings and Class C interior finish for sprinklered buildings shall be permitted.*

*c. Requirements for rooms and enclosed spaces shall be based upon spaces enclosed by partitions. Where a fire-resistance rating is required for structural elements, the enclosing partitions shall extend from the floor to the ceiling. Partitions that do not comply with this shall be considered enclosing spaces and the rooms or spaces on*

*both sides shall be considered one. In determining the applicable requirements for rooms and enclosed spaces, the specific occupancy thereof shall be the governing factor regardless of the group classification of the building or structure.*

- d. Lobby areas in Group A-1, A-2 and A-3 occupancies shall not be less than Class B materials.*
- e. Class C interior finish materials shall be permitted in places of assembly with an occupant load of 300 persons or less.*
- f. For places of religious worship, wood used for ornamental purposes, trusses, paneling or chancel furnishing shall be permitted.*
- g. Class B material is required where the building exceeds two stories.*
- h. Class C interior finish materials shall be permitted in administrative spaces.*
- i. Class C interior finish materials shall be permitted in rooms with a capacity of four persons or less.*
- j. Class B materials shall be permitted as wainscoting extending not more than 48 inches above the finished floor in corridors.*
- k. Finish materials as provided for in other sections of this code.*
- l. Applies when the exit enclosures, exit passageways, corridors or rooms and enclosed spaces are protected by a sprinkler system installed in accordance with Section 903.3.1.1 or 903.3.1.2.*

**a. Exit enclosures and exit passageways**

**b. Corridors**

**c. Rooms and enclosed spaces**

**III. Travel Distance- per Table 1016.1**

<b>OCCUPANCY</b>	<b>WITHOUT SPRINKLER SYSTEM (feet)</b>	<b>WITH SPRINKLER SYSTEM (feet)</b>
R <sup>d</sup>	100 <sup>e</sup>	200 <sup>b</sup>
M	150	250 <sup>c</sup>
A, F-1, I-1	200	250 <sup>b</sup>
B	200	300 <sup>c</sup>
S-1	200	400 <sup>c</sup>
F-2, S-2, U	300	400 <sup>c</sup>
H-1	Not Permitted	75 <sup>c</sup>
H-2	Not Permitted	100 <sup>c</sup>
H-3	Not Permitted	150 <sup>c</sup>
H-4	Not Permitted	175 <sup>c</sup>
H-5	Not Permitted	200 <sup>c</sup>

E, D, S-2 <sup>f</sup> I-2, I-3	150	200 <sup>c</sup>
------------------------------------	-----	------------------

For SI: 1 foot = 304.8 mm.

- a. See the following sections for modifications to exit access travel distance requirements:
  - Section 402: For the distance limitation in malls.
  - Section 404: For the distance limitation through an atrium space.
  - Section 1016.2 For increased limitations in Groups F-1 and S-1.
  - Section 1025.7: For increased limitation in assembly seating.
  - Section 1025.7: For increased limitation for assembly open-air seating.
  - Section 1019.2: For buildings with one exit.
  - Chapter 31: For the limitation in temporary structures.
- b. Buildings equipped throughout with an automatic sprinkler system in accordance with Section 903.3.1.1 or 903.3.1.2. See Section 903 for occupancies where automatic sprinkler systems in accordance with Section 903.3.1.2 are permitted.
- c. Buildings equipped throughout with an automatic sprinkler system in accordance with Section 903.3.1.1.
- d. Travel within a guestroom, guest suite or dwelling unit shall not be included when calculating the travel distance. See Section 1014.3, Exception 4 for common path within.
- e. For exterior 200 feet is allowed without sprinkler.
- f. Enclosed parking garage.

a. **Maximum allowed travel distance**

b. **Actual travel distance**

**IV. Required Separation of Occupancies- per Table 508.3.3**

OCCUPANCY	A <sup>e</sup> , E, D		I		R <sup>d</sup>		F-2, F-3, S-2 <sup>c,d</sup> , U <sup>d</sup>		B <sup>b</sup> , F-1, M <sup>b</sup> , S-1		H-1		H-2		H-3, H-4, H-5	
	S	NS	S	NS	S	NS	S	NS	S	NS	S	NS	S	NS	S	NS
A <sup>e</sup> , E <sup>e</sup> , D	N	N	1	2	1	2	N	1	1	2	NP	NP	3	4	2	3 <sup>a</sup>
I	-	-	N	N	1	NP	1	2	1	2	NP	NP	3	NP	2	NP
R <sup>d</sup>	-	-	-	-	N	N	1	2	1	2	NP	NP	3	NP	2	NP
F-2, F-3, S-2 <sup>c,d</sup> , U <sup>d</sup>	-	-	-	-	-	-	N	N	1	2	NP	NP	3	4	2	3 <sup>a</sup>
B <sup>b</sup> , F-1, M <sup>b</sup> , S-1	-	-	-	-	-	-	-	-	N	N	NP	NP	2	3	1	2 <sup>a</sup>
H-1	-	-	-	-	-	-	-	-	-	-	N	NP	NP	NP	NP	NP

H-2	-	-	-	-	-	-	-	-	-	-	-	-	-	N	NP	1	NP
H-3, H-4, H-5	-	-	-	-	-	-	-	-	-	-	-	-	-	-	-	N	NP

*For SI: 1 square foot = 0.0929 m<sup>2</sup>.*

*S = Buildings equipped throughout with an automatic sprinkler system installed in accordance with Section 903.3.1.1.*

*NS = Buildings not equipped throughout with an automatic sprinkler system installed in accordance with Section 903.3.1.1.*

*N = No separation requirement.*

*NP = Not permitted.*

*a. For Group H-5 occupancies, see Section 903.2.4.2.*

*b. Occupancy separation need not be provided for storage areas within Groups B and M if the:*

- 1. Area is less than 10 percent of the floor area;*
- 2. Area is equipped with an automatic fire-extinguishing system and is less than 3,000 square feet; or*
- 3. Area is less than 1,000 square feet.*

*c. Areas used only for private or pleasure vehicles shall be allowed to reduce separation by 1 hour.*

*d. See Section 406.1.4.*

*e. Commercial kitchens need not be separated from the restaurant seating areas that they serve.*

**a. Incidental use areas- per Table 508.2**

ROOM OR AREA	SEPARATION AND/OR PROTECTION
Furnace room where any piece of equipment is over 400,000 Btu per hour input	1 hour or provide automatic fire-extinguishing system
Rooms with boilers where the largest piece of equipment is over 15 psi and 10 horsepower	1 hour or provide automatic fire-extinguishing system
Refrigerant machinery rooms	1 hour or provide automatic sprinkler system
Parking garage (Section 406.2)	2 hours; or 1 hour and provide automatic fire-extinguishing system
Hydrogen cut-off rooms, not classified as Group H	1-hour in Group B, F, M, S and U occupancies. 2-hour in Group A, E, I and R occupancies.
Incinerator rooms	2 hours and automatic sprinkler

	system
Paint shops, not classified as Group H, located in occupancies other than Group F	2 hours; or 1 hour and provide automatic fire-extinguishing system
Laboratories and vocational shops, not classified as Group H, located in Group E or I-2 occupancies	1 hour or provide automatic fire-extinguishing system
Laundry rooms over 100 square feet	1 hour or provide automatic fire-extinguishing system
Storage rooms over 100 square feet	1 hour or provide automatic fire-extinguishing system
Group I-3 cells equipped with padded surfaces	1 hour
Group I-2 waste and linen collection rooms	1 hour
Waste and linen collection rooms over 100 square feet	1 hour or provide automatic fire-extinguishing system
Stationary storage battery systems having a liquid capacity of more than 100 gallons used for facility standby power, emergency power or uninterrupted power supplies	1-hour in Group B, F, M, S and U occupancies. 2-hour in Group A, E, I and R occupancies.

*For SI: 1 square foot = 0.0929 m<sup>2</sup>, 1 pound per square inch = 6.9 kPa, 1 British thermal unit per hour = 0.293 watts, 1 horsepower = 746 watts, 1 gallon = 3.785 L.*

#### 4. Egress- per FBC-B

##### I. Exits

- a. **Number of Exits-** per Section 1015.1 Exit or exit access doorways required. *Two exits or exit access doorways from any space shall be provided where one of the following conditions exists:*
  1. *The occupant load of the space exceeds the values in Table 1015.1.*

2. The common path of egress travel exceeds the limitations of Section 1014.3.
3. Where required by Sections 1015.3, 1015.4 and 1015.5. Exception: Group I-2 occupancies shall comply with Section 1014.2.2.

- a. **Minimum number of exits per occupant load-** per Table 1019.1

OCCUPANT LOAD (persons per story)	MINIMUM NUMBER OF EXITS (per story)
1-500	2
501-1,000	3
More than 1,000	4

- b. **Spaces with one means of egress-** per Table 1015.1

OCCUPANCY	MAXIMUM OCCUPANT LOAD
A, B, D, E, F, M, U, R-2, R-3	49
H-1, H-2, H-3	3
H-4, H-5, I-1, I-3, R-1, R-4	10
S	29

- c. **Buildings with one exit-** per Table 1019.2

OCCUPANCY	MAXIMUM HEIGHT OF BUILDING ABOVE GRADE PLANE	MAXIMUM OCCUPANTS (OR DWELLING UNITS) PER FLOOR AND TRAVEL DISTANCE
A, B <sup>d</sup> , D, E <sup>e</sup> , F, M, U	1 Story	49 occupants and 75 feet travel distance
H-2, H-3	1 Story	3 occupants and 25 feet travel distance
H-4, H-5, I, R	1 Story	10 occupants and 75 feet travel distance
S <sup>a</sup>	1 Story	29 occupants and 100 feet travel distance
B <sup>b</sup> , F, M, S <sup>a</sup>	2 Stories	30 occupants and 75 feet travel distance
R-2	2 Stories <sup>c</sup>	4 dwelling units and 50 feet travel distance

- b. **Exit location-** per Section 1015.2.1 Two exits or exit access doorways. *Where two exits or exit access doorways are required from any portion of the exit access, the exit doors or exit access doorways shall be placed a distance apart equal to not less than one-half of the length of the maximum overall diagonal dimension of the building or area to be served measured in a straight line between exit doors or exit access doorways. Interlocking or scissor stairs shall be counted as one exit stairway.*



- c. **The Common Path of Egress Travel-** per Section 1014.3-  
*In occupancies other than Groups H-1, H-2 and H-3, the common path of egress travel shall not exceed 75 feet (22 860 mm). In Group H-1, H-2 and H-3 occupancies, the common path of egress travel shall not exceed 25 feet (7620 mm). For common path of egress travel in Group A occupancies having fixed seating, see Section 1025.8.*  
**Exceptions:**
1. *The length of a common path of egress travel in Group B, F, M and S occupancies shall not be more than 100 feet (30 480 mm), provided that the building is equipped throughout with an automatic sprinkler system installed in accordance with Section 903.3.1.1.*
  2. *Where a tenant space in Group B, S and U occupancies has an occupant load of not more than 30, the length of a common path of egress travel shall not be more than 100 feet (30 480 mm).*
  3. *The length of a common path of egress travel in a Group I-3 occupancy shall not be more than 100 feet (30 480 mm).*
  4. *the length of a common path of egress travel in a Group R-2 occupancy shall not be more than 125 feet (38 100 mm), within the dwelling unit, provided that the building is protected throughout with an approved automatic sprinkler system in accordance with Section 903.3.1.1 otherwise 75 feet.*
  5. *Where a tenant space in Group A occupancy has an occupant load of more than 50, the length of a common path of egress travel shall not be more than 20 feet (6098 mm).*
  6. *The common path of egress travel in Group R1 and R2 occupancies shall not exceed 35 feet (10 668 mm). Travel within a guestroom, guest suite or dwelling unit shall not be included when calculating the common path of travel. The common path of egress travel in occupancy Groups R1 and R2 shall not exceed 50 feet (15 240 mm) provided the building is protected throughout by an approved, automatic sprinkler system in accordance with Section 903.3.1.1.*
  7. *The common path of egress travel in occupancies in Group F and S shall be 50 feet (15 240 mm) in unsprinklered buildings.*
  8. *The common path of egress travel in Group S2 parking garages shall be 50 feet (15 240 mm).*
  9. *In occupancy Group S2 common paths of egress travel shall not be limited.*

10. In occupancy Group H common paths of egress travel shall be prohibited.

**II. Corridors**

- a. **Dead End Corridors-** per section Section 1017.3  
*Where more than one exit or exit access doorway is required, the exit access shall be arranged such that there are no dead ends in corridors more than 20 feet (6096 mm) in length.*

*Exceptions:*

- 1. *In occupancies in Group I-3 of Occupancy Condition 2, 3 or 4 (see Section 308.4), the dead end in a corridor shall not exceed 50 feet (15 240 mm).*
- 2. *In occupancies in Groups B and F where the building is equipped throughout with an automatic sprinkler system in accordance with Section 903.3.1.1, the length of dead-end corridors shall not exceed 50 feet (15 240 mm).*
- 3. *A dead-end corridor shall not be limited in length where the length of the dead-end corridor is less than 2.5 times the least width of the dead-end corridor.*

- a. **Maximum Dead End Corridor Length**

- b. **Actual Dead End Corridor Length**

- b. **Corridor width-**

- a. **See ADA III.b.a.**

- b. **Per Table 1005.1**

*Table 1005.1*

OCCUPANCY	WITHOUT SPRINKLER SYSTEM		WITH SPRINKLER SYSTEM <sup>a</sup>	
	Stairways (inches per occupant)	Other egress components (inches per occupant)	Stairways (inches per occupant)	Other egress components (inches per occupant)
Occupancies other than those listed below	0.3	0.2	0.3	0.2
Hazardous: H-1, H-2, H-3 and H-4	0.7	0.4	0.7	0.4
Health care	0.6	0.5	0.3	0.2
Institutional: I-2	NA	NA	0.4	0.2

*For SI: 1 inch = 25.4 mm. NA = Not applicable.*

- a. *Buildings equipped throughout with an automatic sprinkler system in accordance with Section 903.3.1.1 or 903.3.1.2.*

- c. **Section 1017.2**

- 1017.2 Corridor width. The minimum corridor width shall be as determined in Section 1005.1, but not less than 44 inches (1118 mm).*

*Exceptions:*

1. *Twenty-four inches (610 mm)-For access to and utilization of electrical, mechanical or plumbing systems or equipment.*
2. *Thirty-six inches (914 mm)-With a required occupant capacity of less than 50.*
3. *Thirty-six inches (914 mm)-Within a dwelling unit.*
4. *Seventy-two inches (1829 mm)-In Group E with a corridor having a required capacity of 100 or more.*
5. *Seventy-two inches (1829 mm)-In corridors serving surgical Group I, health care centers for ambulatory patients receiving outpatient medical care, which causes the patient to be not capable of self-preservation.*
6. *Ninety-six inches (2438 mm)-In Group I-2 in areas where required for bed movement.*

### III. **Doors**

- a. **Protrusions into the path of travel-** per section 1008.1.8.8

*During its swing, any door in a means of egress shall leave unobstructed at least one half of the required width of an aisle, corridor, passageway or landing, nor project more than 7 inches (178 mm) into the required width of an aisle, corridor, passageway or landing, when fully open. Doors shall not open immediately onto a stair without a landing. The landing shall have a width at least equal to the width of the door. See Section 1027 for door swing in Group E occupancies.*

*Every door in a stair enclosure serving more than four stories shall permit reentry from the stair enclosure to the interior of the building, or an automatic release shall be provided to unlock all stair enclosure doors to permit reentry. Such automatic release shall be actuated with the initiation of the building fire alarm, fire detection or fire sprinkler system.*

*Exception: Doors on stair enclosures shall be permitted to be equipped with hardware that prevents reentry*

*into the interior of the building, provided that the following conditions are met:*

- 1. There are at least two levels where it is possible to leave the stair enclosure;*
- 2. There are not more than four stories intervening between stories where it is possible to leave the stair enclosure;*
- 3. Reentry is possible on the top or next to top story permitting access to another exit;*
- 4. Doors permitting reentry are identified as such on the stair side of the door; and*
- 5. Doors not permitting reentry are provided with a sign on the stair side indicating the location of the nearest door, in each direction of travel, permitting reentry or exit.*

**a. Maximum protrusion**

**b. Actual protrusion**

**b. Thresholds-** per Section 1008.1.6

*Thresholds at doorways shall not exceed 0.75 inch (19.1 mm) in height for sliding doors serving dwelling units or 0.5 inch (12.7 mm) for other doors. Raised thresholds and floor level changes greater than 0.25 inch (6.4 mm) at doorways shall be beveled with a slope not greater than one unit vertical in two units horizontal (50-percent slope).*

*Exceptions:*

- 1. The threshold height shall be limited to 7<sup>3</sup>/<sub>4</sub> inches (197 mm) where the occupancy is Group R-2, the door is an exterior door that is not a component of the required means of egress and the doorway is not on an accessible route. In one- and two-family dwellings where the door discharges to the outside or to an exterior balcony or exterior exit access, the floor level outside the door shall be permitted to be one step lower than the inside, but not more than 8 inches (203 mm) lower.*
- 2. For exterior doors serving dwelling units, thresholds at doorways shall not exceed the height required to pass the water resistance test of ANSI/AAMA/WDMA 101/I.S.2, or TAS 202 for high-velocity hurricane zones, or the maximum allowable height difference between*

*interior floor level. Exterior floor level shall comply with the following:*

<b>LEVEL DIFFERENCE (inches)</b>	<b>AT PRIMARY DOOR</b>
0	Pervious construction (e.g., wood decking with spaces)
1/2	Impervious construction (e.g., concrete, brick or flag stone)
<b>LEVEL DIFFERENCE (inches)</b>	<b>AT SECONDARY DOOR</b>
1/2	Pervious construction
4	Impervious construction

c. **See ADA III.a.**

IV. **Stairs**

a. **Stairway Egress width-** per Section 1009.1

*The width of stairways shall be determined as specified in Section 1005.1, but such width shall not be less than 44 inches (1118 mm). See Section 1007.1 for accessible means of egress stairways.*

*Exceptions:*

1. *Stairways serving an occupant load of less than 50 shall have a width of not less than 36 inches (914 mm).*
2. *Spiral stairways as provided for in Section 1009.8.*
3. *Aisle stairs complying with Section 1025.*
4. *Where an incline platform lift or stairway chairlift is installed on stairways serving occupancies in Group R-3, or within dwelling units in occupancies in Group R-2, a clear passage width not less than 20 inches (508 mm) shall be provided. If the seat and platform can be folded when not in use, the distance shall be measured from the folded position.*

b. **Risers-** per Section 1009.3

*Stair riser heights shall be 7 inches (178 mm) maximum and 4 inches (102 mm) minimum. Stair tread depths shall be 11 inches (279 mm) minimum. The riser height shall be measured vertically between the leading edges of adjacent treads. The tread depth shall be measured horizontally between the vertical planes of the foremost projection of adjacent treads and at a right angle to the tread's leading edge. Winder treads shall have a minimum tread depth of 11 inches (279 mm) measured at a right angle to the tread's leading edge at a point 12*

*inches (305 mm) from the side where the treads are narrower and a minimum tread depth of 10 inches (254 mm).*

*Exceptions:*

- 1. Alternating tread devices in accordance with Section 1009.9.*
- 2. Spiral stairways in accordance with Section 1009.8.*
- 3. Aisle stairs in assembly seating areas where the stair pitch or slope is set, for sightline reasons, by the slope of the adjacent seating area in accordance with Section 1025.11.2.*
- 4. In occupancies in Group R-3, as applicable in Section 101.2, within dwelling units in occupancies in Group R-2, as applicable in Section 101.2, and in occupancies in Group U, which are accessory to an occupancy in Group R-3, as applicable in Section 101.2, the maximum riser height shall be 7.75 inches (197 mm) and the minimum tread depth, exclusive of nosing, shall be not less than 9 inches (229 mm), the minimum winder tread depth at the walk line shall be 10 inches (254 mm), and the minimum winder tread depth shall be 6 inches (152 mm). Treads and risers of stairs shall be permitted to be so proportioned that the sum of two risers and a tread, exclusive of projection of nosing, is not less than 24 inches (610 mm) nor more than 25 inches (635 mm). Every tread less than 10 inches (254 mm) wide shall have a nosing, or effective projection, of approximately 1 inch (25 mm) over the level immediately below that tread.*
- 5. See the Florida Building Code, Existing Building for the replacement of existing stairways.*
- 6. Industrial equipment access stairs and landings that serve as a component of the means of egress from the involved equipment and do not serve more than 20 people shall be permitted to have a minimum clear width of 22 inches (559 mm), minimum tread depth of 10 inches (254 mm), maximum riser height of 9 inches (229 mm), minimum*

*headroom of 6 feet 8 inches (2032 mm), and a maximum height between landings of 12 feet (36 576 mm).*

*1009.3.1 Winder treads. Winder treads are not permitted in means of egress stairways except within a dwelling unit.*

*Exceptions:*

- 1. Curved stairways in accordance with Section 1009.7.*
- 2. Spiral stairways in accordance with Section 1009.8.*

*1009.3.2 Dimensional uniformity. Stair treads and risers shall be of uniform size and shape. The tolerance between the largest and smallest riser height or between the largest and smallest tread depth shall not exceed 0.375 inch (9.5 mm) in any flight of stairs. The greatest winder tread depth at the 12-inch (305 mm) walk line within any flight of stairs shall not exceed the smallest by more than 0.375 inch (9.5 mm) measured at a right angle to the tread's leading edge.*

*Exceptions:*

- 1. Nonuniform riser dimensions of aisle stairs complying with Section 1025.11.2.*
- 2. Consistently shaped winders, complying with Section 1009.3, differing from rectangular treads in the same stairway flight. Where the bottom or top riser adjoins a sloping public way, walkway or driveway having an established grade and serving as a landing, the bottom or top riser is permitted to be reduced along the slope to less than 4 inches (102 mm) in height, with the variation in height of the bottom or top riser not to exceed one unit vertical in 12 units horizontal (8.333-percent slope) of stairway width. The nosings or leading edges of treads at such nonuniform height risers shall have a distinctive marking stripe, different from any other nosing marking provided on the stair flight. The distinctive marking stripe shall be visible in descent of the stair and shall have a slip-resistant surface. Marking stripes shall have a width of at least 1 inch (25 mm) but not more than 2 inches (51 mm).*

*1009.3.3 Profile. The radius of curvature at the leading edge of the tread shall be not greater than 0.5 inch (12.7 mm). Beveling of nosings shall not exceed 0.5 inch (12.7 mm). Risers shall be solid and vertical or sloped from the underside of the leading edge of the tread above at an angle not more than 30 degrees (0.52 rad) from the vertical. The leading edge (nosings) of treads shall project not more than 1.25 inches (32 mm) beyond the tread below and all projections of the leading edges shall be of uniform size, including the leading edge of the floor at the top of a flight.*

*Exceptions:*

- 1. Solid risers are not required for stairways that are not required to comply with Section 1007.3, provided that the opening between treads does not permit the passage of a sphere with a diameter of 4 inches (102 mm).*
- 2. Solid risers are not required for occupancies in Group I-3.*

*1009.3.4 Tread slope shall not be more than  $\frac{1}{4}$  inch per foot (21 mm/m).*

- a. **Minimum height-**
- b. **Maximum height-**
- c. **Actual height-**
- d. **See ADA III.c.b.**
- c. **Treads-** per Section 1009.3
  - a. **Minimum depth-**
  - b. **Actual depth-**
  - c. **See ADA III.c.b.**
- d. **Minimum headroom within stairwell-** per Section 1009.2  
*Stairways shall have a minimum headroom clearance of 80 inches (2032 mm) measured vertically from a line connecting the edge of the nosings. Such headroom shall be continuous above the stairway to the point where the line intersects the landing below, one tread depth beyond the bottom riser. The minimum clearance shall be maintained the full width of the stairway and landing.*  
*Exception: Spiral stairways complying with Section 1009.8 are permitted a 78-inch (1981 mm) headroom clearance.*
- e. **Landings-** per Section 1009.4  
*There shall be a floor or landing at the top and bottom of each stairway. The width of landings shall not be*



*less than the width of stairways they serve. Every landing shall have a minimum dimension measured in the direction of travel equal to the width of the stairway. Such dimension need not exceed 48 inches (1219 mm) where the stairway has a straight run.*

*Exceptions:*

- 1. Aisle stairs complying with Section 1024.*
- 2. Doors opening onto a landing shall not reduce the landing to less than one-half the required width. When fully open, the door shall not project more than 7 inches (178 mm) into a landing.*
- 3. In one- and two-family dwellings, a door at the top of a stair shall be permitted to open directly at a stair, provided the door does not swing over the stair and the door serves an area with an occupant load of fewer than 50 persons.*

V. **Ramps**- See ADA III.e.

5. **Americans with Disabilities Act (ADA)**- per FBC-B chapter 11

I. **General**

a. **Protruding objects**- per section 11-4.4

*11-4.4.1 General. Objects projecting from walls (for example, telephones) with their leading edges between 27 inches and 80 inches (685 mm and 2030 mm) above the finished floor shall protrude no more than 4 inches (102 mm) into walks, halls, corridors, passageways, or aisles [see Figure 8(a)]. Objects mounted with their leading edges at or below 27 inches (685 mm) above the finished floor may protrude any amount [see Figure 8(a) and Figure 8(b)]. Free-standing objects mounted on posts or pylons may overhang 12 in (305 mm) maximum from 27 inches to 80 inches (685 mm to 2030 mm) above the ground or finished floor [see Figure 8(c) and Figure 8(d)]. Protruding objects shall not reduce the clear width of an accessible route or maneuvering space [see Figure 8(e)].*

*11-4.4.2 Headroom. Walks, halls, corridors, passageways, aisles, or other circulation spaces shall have 80 inches (2030 mm) minimum clear head room [see Figure 8(a)]. If vertical clearance of an area adjoining an accessible route is reduced to less than 80 inches (2032 mm) (nominal dimension), a barrier to warn blind or*

*visually-impaired persons shall be provided [see Figure 8(c-1)].*

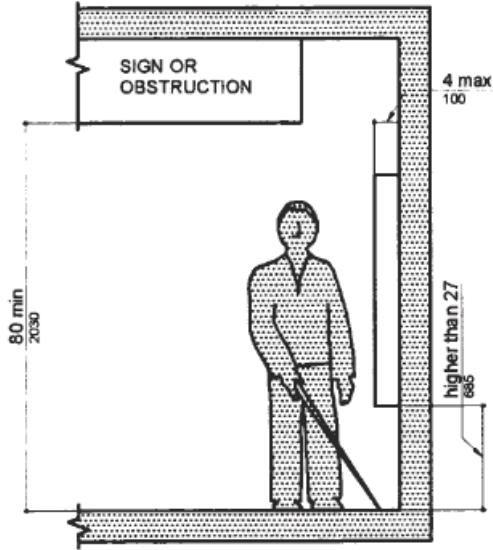

(a)  
Walking Parallel to a Wall

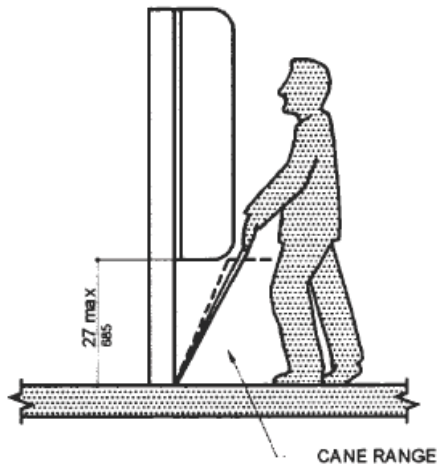
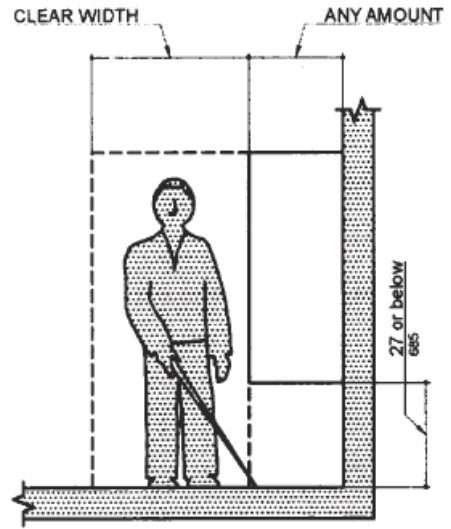

(b)  
Walking Perpendicular to a Wall

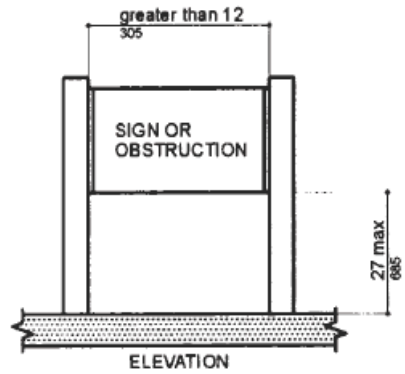
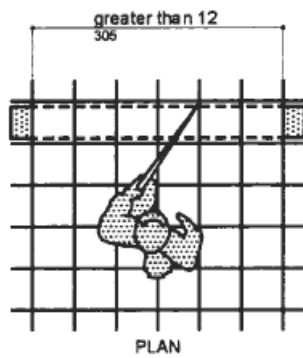

(c)  
Free-Standing Overhanging Objects

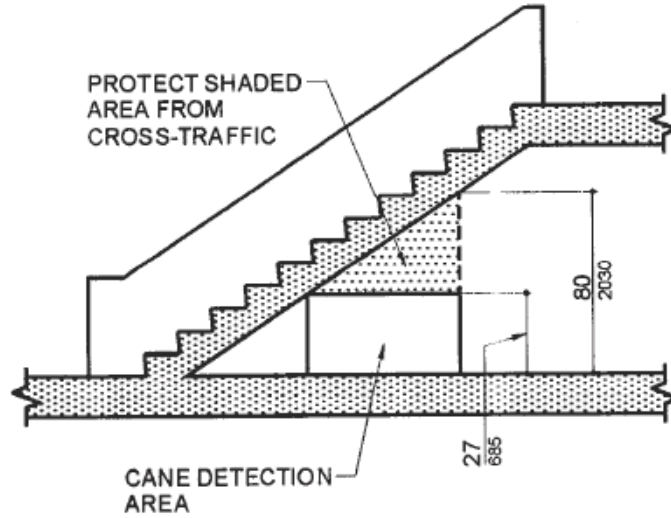

(c-1)  
Overhead Hazards

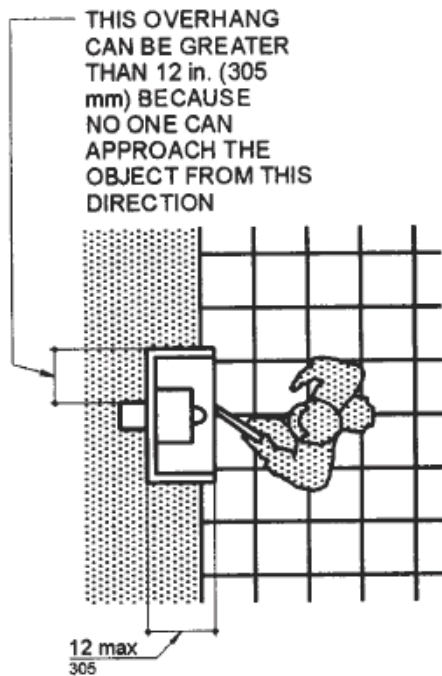

PLAN

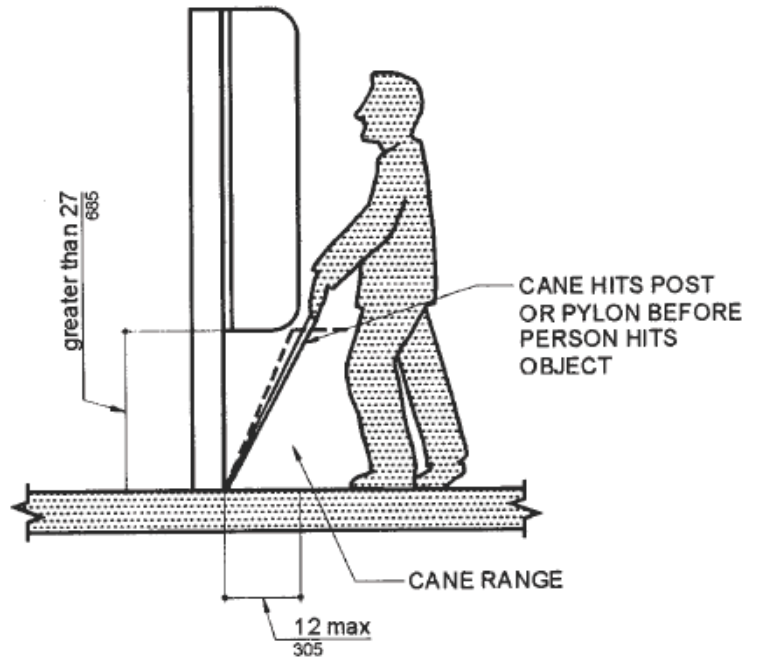

ELEVATION

(d)  
Objects Mounted on Posts or Pylons

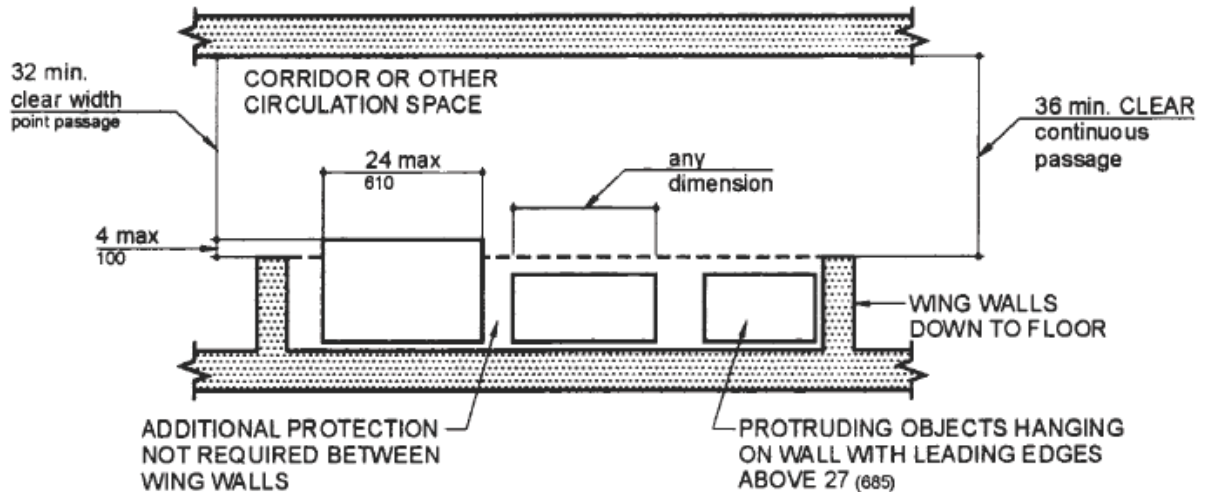

(e)  
Example of Protection Around Wall-Mounted Objects  
and Measurements of Clear Widths

**b. Sales and service counters, teller windows, information counters-** per section 11-7.2

(1) *In department stores and miscellaneous retail stores where counters have cash registers and are provided for sales or distribution of goods or services to the public, at least one of each type shall have a portion of the counter which is at least 36 inches (915 mm) in length with a maximum height of 36 inches (915 mm) above the finish floor. It shall be on an accessible route complying with Section 11-4.3. The accessible counters must be dispersed throughout the building or facility. In alterations where it is technically infeasible to provide an accessible counter, an auxiliary counter meeting these requirements may be provided.*

(2) *At ticketing counters, teller stations in a bank, registration counters in hotels and motels, box office ticket counters, and other counters that may not have a cash register but at which goods or services are sold or distributed, either:*

*(i) A portion of the main counter which is a minimum of 36 inches (915 mm) in length shall be provided with a maximum height of 36 inches (915 mm); or*

*(ii) An auxiliary counter with a maximum height of 36 in (915 mm) in close proximity to the main counter shall be provided; or*

- (iii) *Equivalent facilitation shall be provided (e.g., at a hotel registration counter, equivalent facilitation might consist of:*
- (1) *Provision of a folding shelf attached to the main counter on which an individual with disabilities can write, and*
  - (2) *Use of the space on the side of the counter or at the concierge desk, for handing materials back and forth). All accessible sales and service counters shall be on an accessible route complying with Section 11-4.3.*

II. **Drinking fountains-** per Section 11-4.1.2(10)

- (a) *Where only one drinking fountain is provided on a floor, there shall be a drinking fountain which is accessible to individuals who use wheelchairs in accordance with Section 11-4.15 and one accessible to those who have difficulty bending or stooping. (This can be accommodated by the use of a "hi-lo" fountain; by providing one fountain accessible to those who use wheelchairs and one fountain at a standard height convenient for those who have difficulty bending; by providing a fountain accessible under Section 11-4.15 and a water cooler; or by such other means as would achieve the required accessibility for each group on each floor.)*
- (b) *Where more than one drinking fountain or water cooler is provided on a floor, at least 50 percent of those provided shall comply with Section 11-4.15 and shall be on an accessible route.*

a. **Clearances-** per section 11-4.15.5

- (1) *Wall- and post-mounted cantilevered units shall have a clear knee space between the bottom of the apron and the floor or ground at least 27 inches (685 mm) high, 30 inches (760 mm) wide, and 17 inches to 19 inches (430 mm to 485 mm) deep [see Figure 27(a) and Figure 27(b)]. Such units shall also have a minimum clear floor space 30 inches by 48 inches (760 mm by 1219 mm) to allow a person in a wheelchair to approach the unit facing forward.*

*(2) Free-standing or built-in units not having a clear space under them shall have a clear floor space at least 30 inches by 48 inches (760 mm by 1219 mm) that allows a person in a wheelchair to make a parallel approach to the unit [see Figure 27(c) and Figure 27(d)]. This clear floor space shall comply with Section 11-4.2.4.*

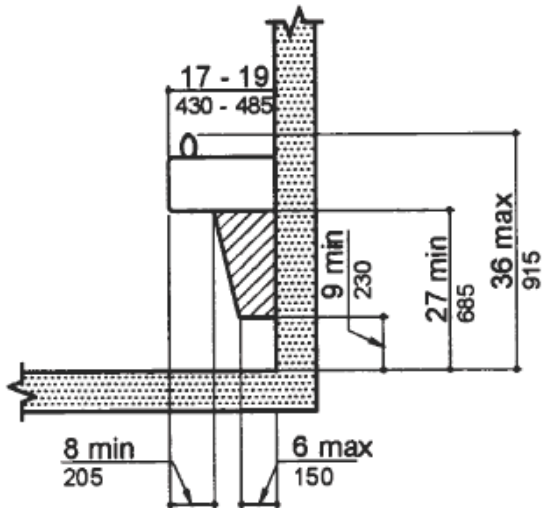

NOTE: Equipment permitted in shaded area

(a)  
Spout Height  
and Knee Clearance

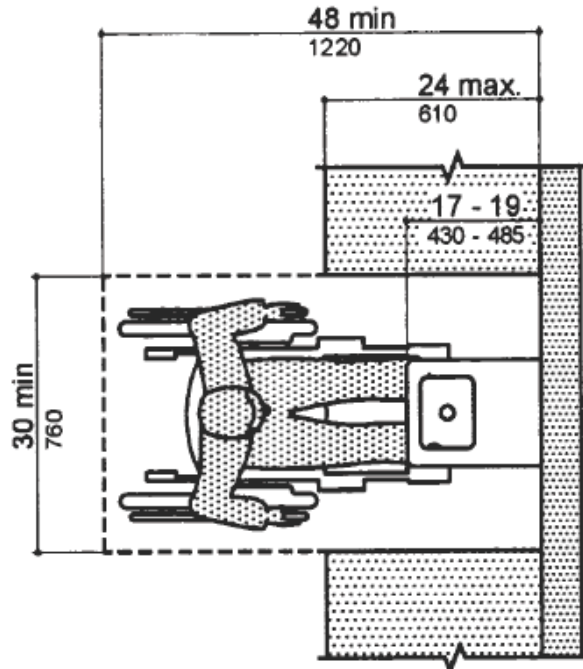

(b)  
Clear Floor Space

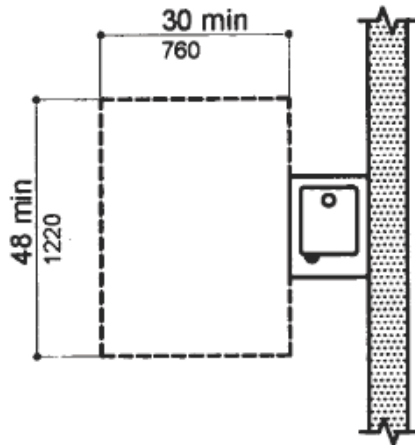

(c)  
Free-Standing  
Fountain or Cooler

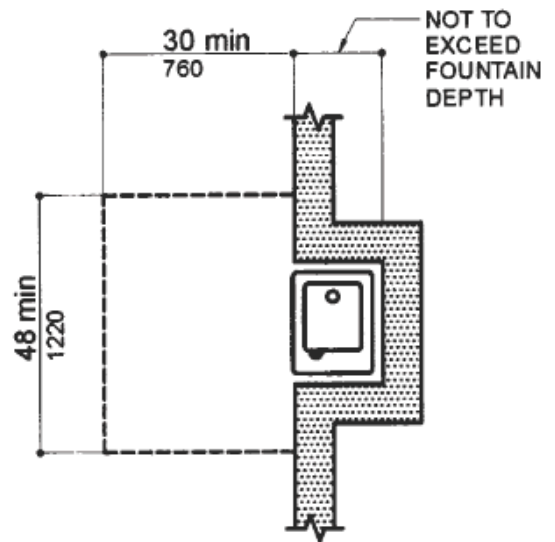

(d)  
Built-in  
Fountain or Cooler

### III. Egress

#### a. Doors

a. General- per section 11-4.13.1



(1) *Doors required to be accessible by Section 11-4.1 shall comply with the requirements of Section 11-4.13.*

(2) *All required doors and walk through openings in buildings excluding single family homes, duplexes, and triplexes not covered by the Americans with Disabilities Act of 1990 or the Fair Housing Act shall have at least 29 inches (737 mm) of clear width. [see Section 11-4.22.2(1), exception].*

**b. Clear width-** per section 11-4.13.5

*Doorways shall have a minimum clear opening of 32 inches (813 mm) with the door open 90 degrees, measured between the face of the door and the opposite stop [see Figure 24(a), Figure 24(b), Figure 24(c), and Figure 24(d)]. Openings more than 24 inches (610 mm) in depth shall comply with Sections 11-4.2.1 and 11-4.3.3 [see Figure 24(e)].*

*Exception: Doors not requiring full user passage, such as shallow closets, may have the clear opening reduced to 20 inches (510 mm) minimum.*

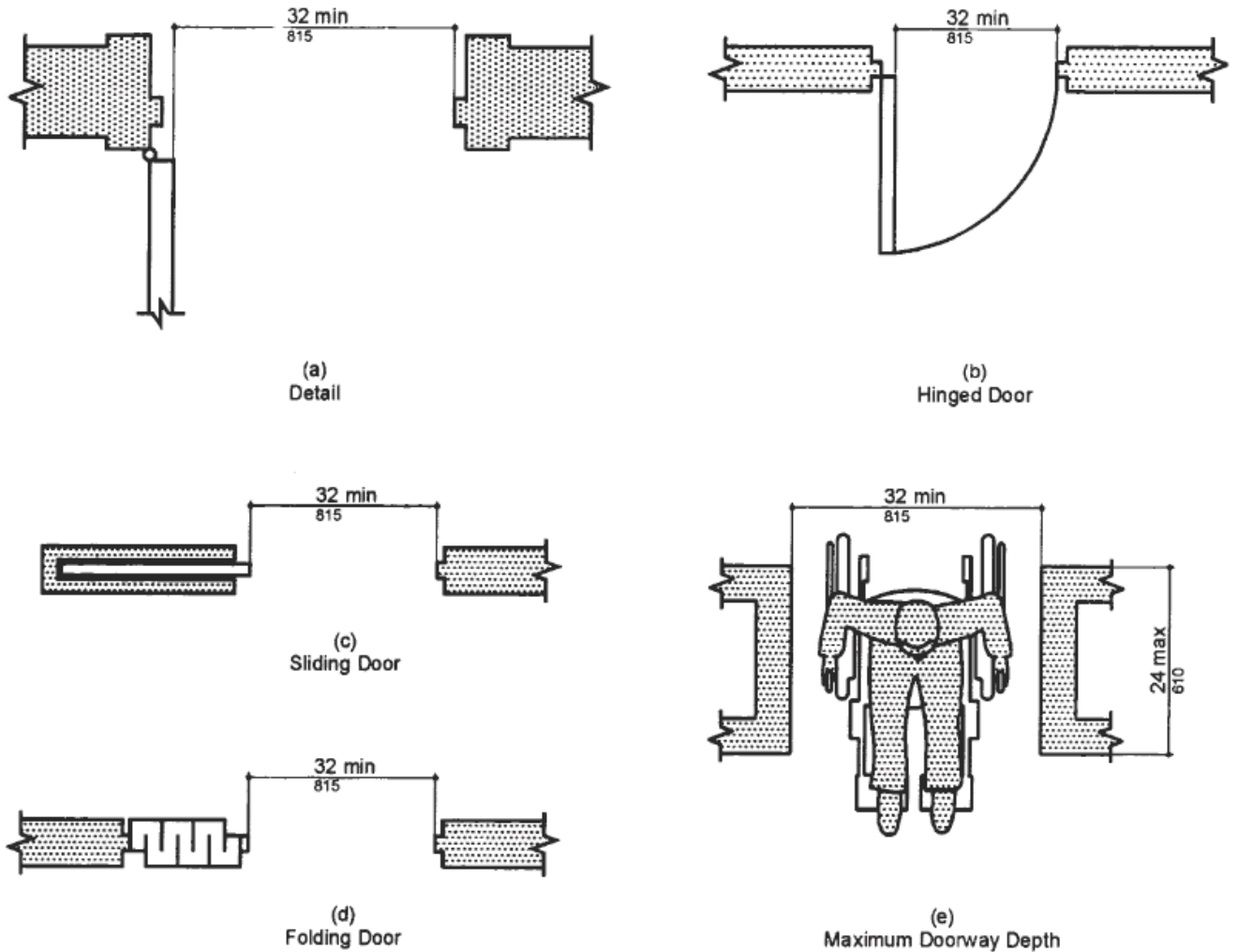

**c. Maneuvering clearances at doors-** per section 11-4.13.6

*Minimum maneuvering clearances at doors that are not automatic or power-assisted shall be as shown in Figure 25. The floor or ground area within the required clearances shall be level and clear.*

*Exception: Entry doors to acute care hospital bedrooms for in-patients shall be exempted from the requirement for space at the latch side of the door (see dimension "x" in Figure 25) if the door is at least 44 inches (1120 mm) wide.*

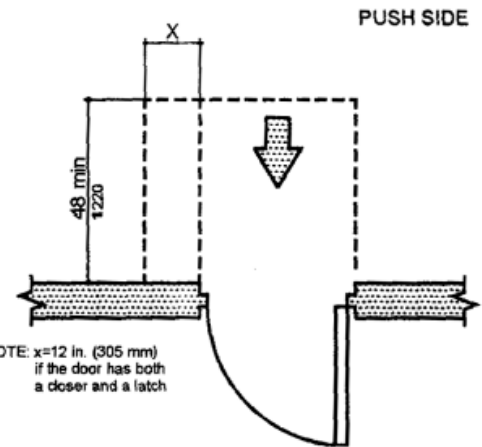
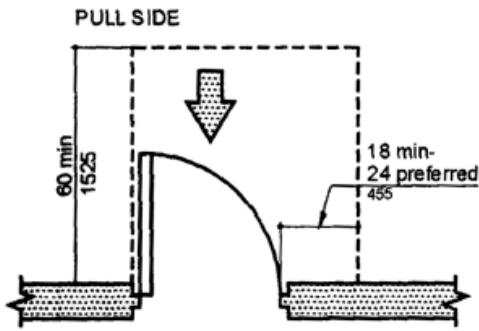

(a)  
Front Approaches - Swinging Doors

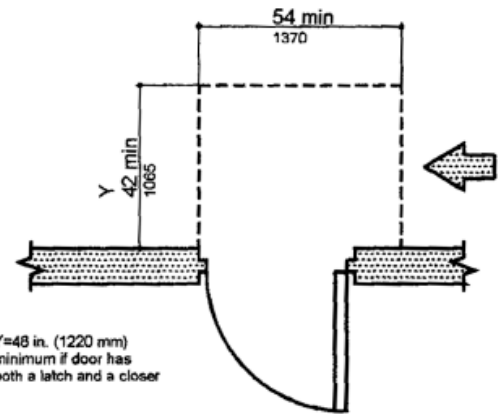
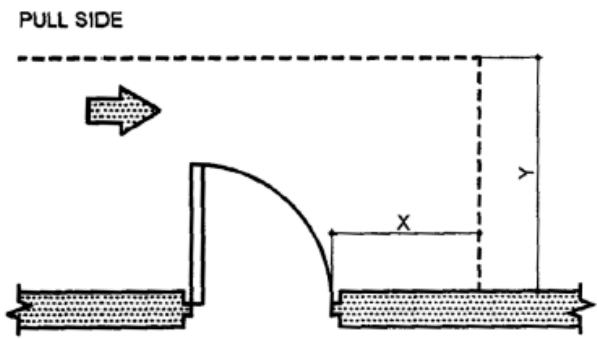

(b)  
Hinge-side Approaches - Swinging Doors

NOTE: All doors in alcoves shall comply with the clearances for front approaches.

- d. **Door hardware-** per section 11-4.13.9  
*Handles, pulls, latches, locks, and other operating devices on accessible doors shall have a shape that is easy to grasp with one hand and does not require tight grasping, tight pinching, or twisting of the wrist to operate. Lever-operated mechanisms, push-type mechanisms, and U-shaped handles are acceptable designs. When sliding doors are fully open, operating hardware shall be exposed and usable from both sides. Hardware required for accessible door*

*passage shall be mounted no higher than 48 inches (1219 mm) above finish floor.*

- e. Egress/ Entrance doors-** per section 11-4.1.3 (8)  
*In new construction, at a minimum, the requirements in Section 11-4.1.3(8)(a) and Section 11-4.1.3(8)(b) below shall be satisfied independently:*

*(a)(i) At least 50 percent of all public entrances [excluding those in Section 11-4.1.3(8)(b) below] must be accessible. At least one must be a ground-floor entrance. Public entrances are any entrances that are not loading or service entrances.*

*(ii) Accessible entrances must be provided in a number at least equivalent to the number of exits required by the applicable building/fire codes. (This paragraph does not require an increase in the total number of entrances planned for a facility.)*

*(iii) An accessible entrance must be provided to each tenancy in a facility (for example, individual stores in a strip shopping center).*

*One entrance may be considered as meeting more than one of the requirements in Section 11-4.1.3(8)(a). Where feasible, accessible entrances shall be the entrances used by the majority of people visiting or working in the building.*

*(b)(i) In addition, if direct access is provided for pedestrians from an enclosed parking garage to the building, at least one direct entrance from the garage to the building must be accessible.*

*(ii) If access is provided for pedestrians from a pedestrian tunnel or elevated walkway, one entrance to the building from each tunnel or walkway must be accessible.*

*One entrance may be considered as*

*meeting more than one of the requirements in Section 11-4.1.3(8)(b).*

*Because entrances also serve as emergency exits whose proximity to all parts of buildings and facilities is essential, it is preferable that all entrances be accessible.*

*(c) If the only entrance to a building, or tenancy in a facility, is a service entrance, that entrance shall be accessible.*

*(d) Entrances which are not accessible shall have directional signage complying with Sections 11-4.30.1, 11-4.30.2, 11-4.30.3, and 11-4.30.5, which indicates the location of the nearest accessible entrance.*

**b. Corridor**

**a. Widths-** per Section 11-4.3.3

*The minimum clear width of an accessible route shall be 36 inches (915 mm) except at doors (see Section 11-4.13.5 and 11-4.13.6). If a person in a wheelchair must make a turn around an obstruction, the minimum clear width of the accessible route shall be as shown in Figure 7(a) and Figure 7(b).*

*Exception: Curb ramps that are a part of a required means of egress shall be not less than 44 inches (1118 mm) wide.*

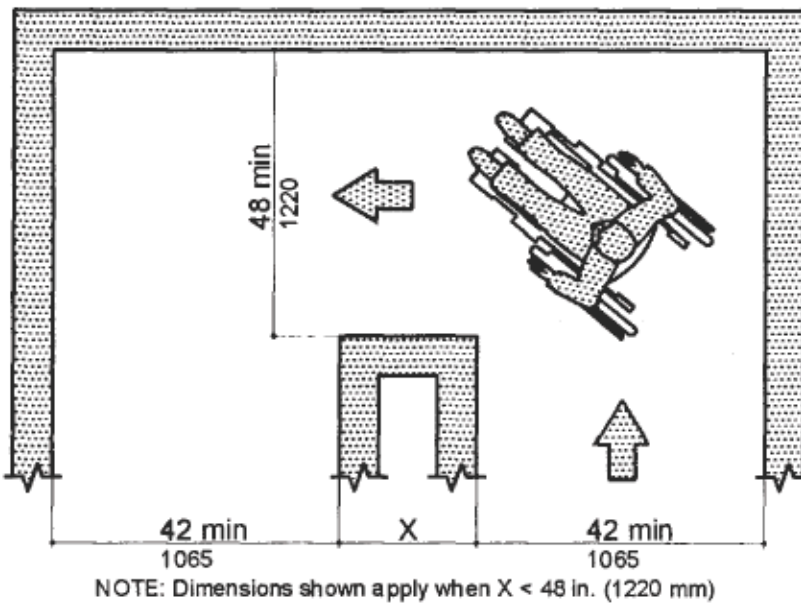
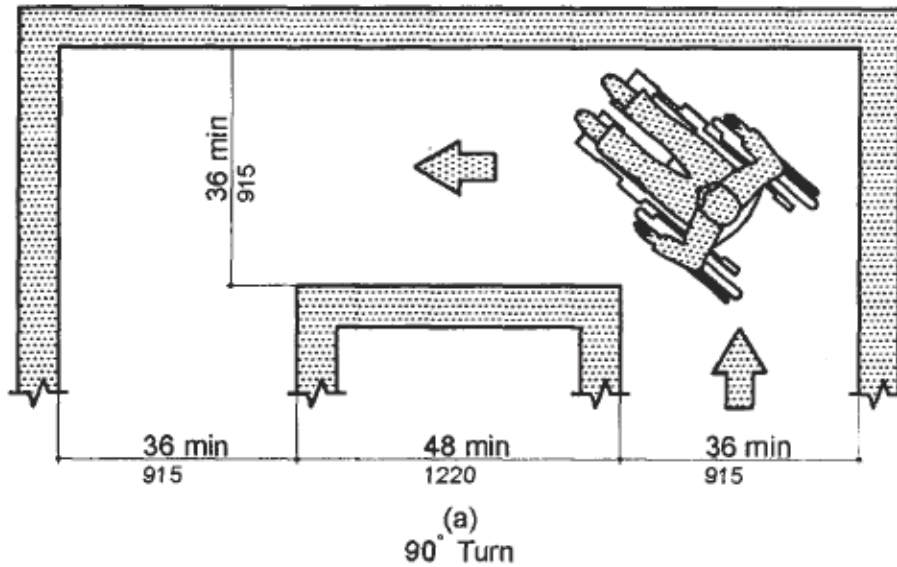

(b)  
Turns Around an Obstruction

**b. Passing space-** per Section 11-4.3.4

*If an accessible route has less than 60 inches (1525 mm) clear width, then passing spaces at least 60 inches by 60 inches (1525 mm by 1525 mm) shall be located at reasonable intervals not to exceed 200 feet (61 m). A T-intersection of two corridors or walks is an acceptable passing place.*

c. **Stairs**

a. **Minimum number**- per Section 11-4.9.1

*Stairs required to be accessible by Section 11-4.1 shall comply with Section 11-4.9.*

b. **Treads and risers**- per Section 11-4.9.2

*On any given flight of stairs, all steps shall have uniform riser heights and uniform tread widths. Stair treads shall be no less than 11 inches (280 mm) wide, measured from riser to riser [see Figure 18(a)]. Open risers are not permitted.*

c. **Nosings**- per Section 11-4.9.3

*The undersides of nosing shall not be abrupt. The radius of curvature at the leading edge of the tread shall be no greater than  $1\frac{1}{2}$  inch (13 mm). Risers shall be sloped or the underside of the nosing shall have an angle not less than 60 degrees from the horizontal. Nosing shall project no more than  $1\frac{1}{2}$  inches (38 mm) (see Figure 18).*

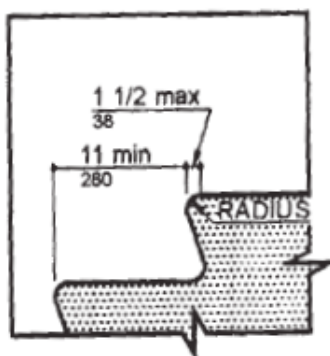

(a)  
Flush Riser

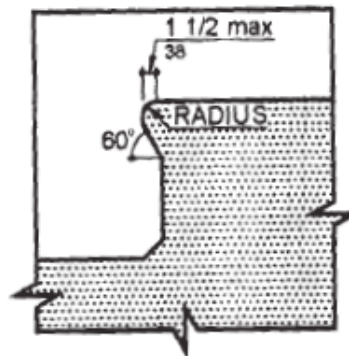

(b)  
Angled Nosing

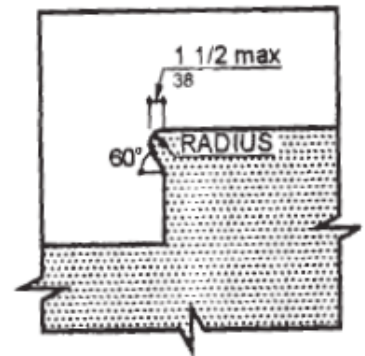

(c)  
Rounded Nosing

d. **Handrails**- per Section 11-4.9.4

*Stairways shall have handrails at both sides of all stairs. Handrails shall comply with Section 11-4.26 and shall have the following features:*

- (1) *Handrails shall be continuous along both sides of stairs. The inside handrail on switchback or dogleg stairs shall always be continuous [see Figure 19(a) and Figure 19(b)].*
- (2) *If handrails are not continuous, they shall extend at least 12 inches (305 mm) beyond the top riser and at least 12 inches (305 mm) plus the width of one tread beyond the bottom riser. At the*

*top, the extension shall be parallel with the floor or ground surface. At the bottom, the handrail shall continue to slope for a distance of the width of one tread from the bottom riser; the remainder of the extension shall be horizontal [see Figure 19(c) and Figure 19(d)]. Handrail extensions shall comply with Section 11-4.4.*

- (3) The clear space between handrails and wall shall be 1½ inches (38 mm).*
- (4) Gripping surfaces shall be uninterrupted by newel posts, other construction elements, or obstructions.*
- (5) Top of handrail gripping surface shall be mounted between 34 inches and 38 inches (865 mm and 965 mm) above stair nosing.*
- (6) Ends of handrails shall be either rounded or returned smoothly to floor, wall or post.*
- (7) Handrails shall not rotate within their fittings.*



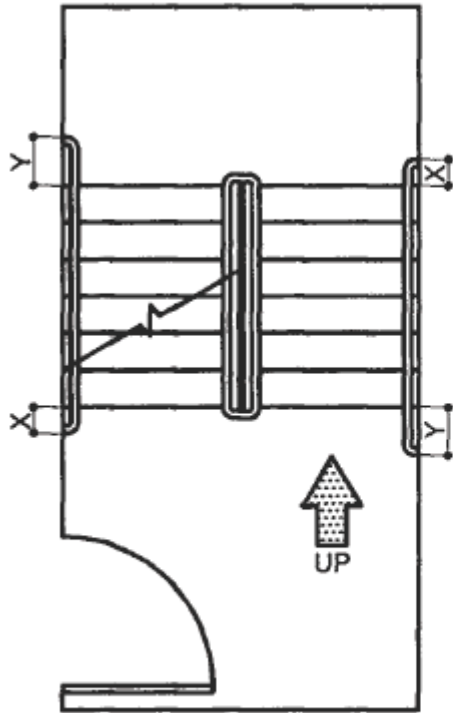

(a)  
Plan

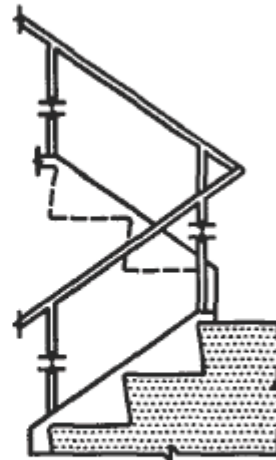

(b)  
Elevation of  
Center Handrail

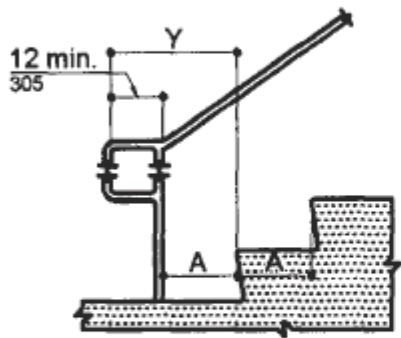

(c)  
Extension at  
Bottom of Run

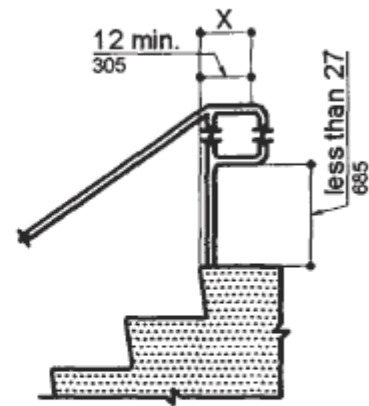

(d)  
Extension at  
Top of Run

NOTE: X IS THE 12 IN. MINIMUM HANDRAIL EXTENSION  
REQUIRED AT EACH TOP RISER

Y IS THE MINIMUM HANDRAIL EXTENSION OF 12 IN.  
PLUS THE WIDTH OF ONE TREAD THAT IS  
REQUIRED AT EACH BOTTOM RISER.

e. **Outdoor conditions-** per Section 11-4.9.6

*Outdoor stairs and their approaches shall be designed so that water will not accumulate on walking surfaces.*

**d. Area of rescue assist**

**a. Location and construction-** per Section 11-4.3.11.1

*An area of rescue assistance shall be one of the following:*

- (1) A portion of a stairway landing within a smokeproof enclosure (complying with local requirements).*
- (2) A portion of an exterior exit balcony located immediately adjacent to an exit stairway when the balcony complies with local requirements for exterior exit balconies. Openings to the interior of the building located within 20 feet (6 m) of the area of rescue assistance shall be protected with fire assemblies having a  $3/4$  hour fire protection rating.*
- (3) A portion of a 1-hour fire-resistive corridor (complying with local requirements for fire-resistive construction and for openings) located immediately adjacent to an exit enclosure.*
- (4) A vestibule located immediately adjacent to an exit enclosure and constructed to the same fire-resistive standards as required for corridors and openings.*
- (5) A portion of a stairway landing within an exit enclosure which is vented to the exterior and is separated from the interior of the building with not less than 1-hour fire-resistive doors.*
- (6) When approved by the appropriate local authority, an area or a room which is separated from other portions of the building by a smoke barrier. Smoke barriers shall have a fire-resistive rating of not less than one hour and shall completely enclose the area or room. Doors in the smoke barrier shall be tight-fitting smoke-and-draft control assemblies having a fire protection rating of not less than 20 minutes and shall be self-closing or automatic closing. The area or room shall be*

*provided with an exit directly to an exit enclosure. Where the room or area exits into an exit enclosure which is required to be of more than 1-hour fire-resistive construction, the room or area shall have the same fire-resistive construction, including the same opening protection, as required for the adjacent exit enclosure.*

*(7) An elevator lobby when elevator shafts and adjacent lobbies are pressurized as required for smokeproof enclosures by local regulations and when complying with requirements herein for size, communication, and signage. Such pressurization system shall be activated by smoke detectors on each floor located in a manner approved by the appropriate local authority. Pressurization equipment and its duct work within the building shall be separated from other portions of the building by a minimum 2-hour fire-resistive construction.*

**b. Size-** per Section 11-4.3.11.2

*Each area of rescue assistance shall provide at least two accessible areas each being not less than 30 inches by 48 inches (760 mm by 1220 mm). The area of rescue assistance shall not encroach on any required exit width. The total number of such 30-inch by 48-inch (760 mm by 1220 mm) areas per story shall be not less than one for every 200 persons of calculated occupant load served by the area of rescue assistance.*

*Exception: The appropriate local authority may reduce the minimum number of 30-inch by 48-inch (760 mm by 1220 mm) areas to one for each area of rescue assistance on floors where the occupant load is less than 200.*

**c. Stairway width-** per Section 11-4.3.11.3

*Each stairway adjacent to an area of rescue assistance shall have a minimum clear width of 48 (1220 mm) inches between handrails.*

**d. Two-way communication-** per Section 11-4.3.11.4

*A method of two-way communication, with both visible and audible signals, shall be provided between each area of rescue assistance and the primary entry. The fire department or appropriate local authority may approve a location other than the primary entry.*

**e. Identification-** per Section 11-4.3.11.5

*Each area of rescue assistance shall be identified by a sign, which states "AREA OF RESCUE ASSISTANCE" and displays the International Symbol of Accessibility. The sign shall be illuminated when exit sign illumination is required. Signage shall also be installed at all inaccessible exits and where otherwise necessary to clearly indicate the direction to areas of rescue assistance. In each area of rescue assistance, instructions on the use of the area under emergency conditions shall be posted adjoining the two-way communication system.*

**e. Ramps**

**a. General-** per Section 11.4.8.1

*Any part of an accessible route with a slope greater than 1:20 shall be considered a ramp and shall comply with Section 11-4.8.*

**b. Slope and Rise-** per Section 11-4.8.2

*The least possible slope shall be used for any ramp. The maximum slope of a ramp in new construction shall be 1 to 12. The maximum rise for any run shall be 30 inches (760 mm) (see Figure 16). Curb ramps and ramps to be constructed on existing sites or in existing buildings or facilities may have slopes and rises as shown as allowed in Section 11-4.1.6(3)(a) if space limitations prohibit the use of a 1 to 12 slope or less (see Section 11-4.1.6).*

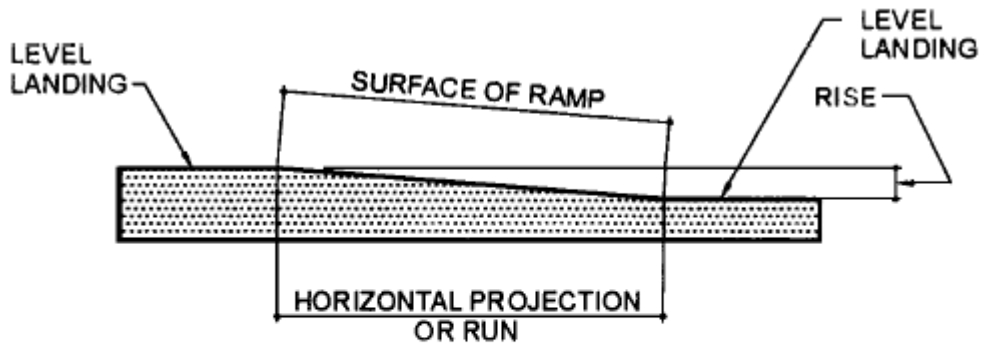

Slope	Maximum Rise		Maximum Horizontal Projection	
	in.	mm	ft	m
1:12 to < 1:16	30	760	30	9
1:16 to < 1:20	30	760	40	12

- c. **Clear Width-** per Section 11-4.8.3  
*The minimum clear width of a ramp shall be 36 inches (915 mm).*  
*Exception: Ramps that are part of a required means of egress shall be not less than 44 inches wide (1118 mm).*
- d. **Landings-** per Section 11.4.8.4  
*Ramps shall have level landings at bottom and top of each ramp and each ramp run. Landings shall have the following features:*
- (1) *The landing shall be at least as wide as the ramp run leading to it.*
  - (2) *All landings on ramps shall be not less than 60 inches (1524 mm) clear, and the bottom of each ramp shall have not less than 72 inches (1829 mm) of straight and level clearance.*
  - (3) *If ramps change direction at landings, the minimum landing size shall be 60 inches by 60 inches (1525 mm by 1525 mm).*
  - (4) *If a doorway is located at a landing, then the area in front of the doorway shall comply with Section 11-4.13.6.*
- e. **Handrails-** per Section 11.4.8.5  
*If a ramp run has a rise greater than 6 inches (150 mm) or a horizontal projection greater than 72 inches (1830 mm), then it shall have handrails on both sides. Handrails are not required on curb ramps or adjacent to seating in assembly areas. Handrails shall comply*

with Section 11-4.26 and shall have the following features:

- (1) Handrails shall be provided along both sides of ramp segments. The inside handrail on switchback or dogleg ramps shall always be continuous.
  - (2) Handrails on ramps which are not continuous shall extend not less than 18 inches (457 mm) beyond the sloped segment at both the top and bottom, and shall be parallel to the floor or ground surface.
  - (3) The clear space between the handrail and the wall shall be 1<sup>1</sup>/<sub>2</sub> inches (38 mm).
  - (4) Gripping surfaces shall be continuous.
  - (5) Top of handrail gripping surfaces shall be mounted between 34 inches and 38 inches (865 mm and 965 mm) above ramp surfaces.
  - (6) Ends of handrails shall be either rounded or returned smoothly to floor, wall, or post.
  - (7) Handrails shall not rotate within their fittings.
- f. **Cross slope and surfaces-** per Section 11-4.8.6  
*The cross slope of ramp surfaces shall be no greater than 1:50. Ramp surfaces shall comply with Section 11-4.5.*
- g. **Edge protection-** per Section 11-4.8.7  
*Ramps and landings with drop-offs shall have curbs, walls, railings, or projecting surfaces that prevent people from slipping off the ramp. Curbs shall be a minimum of 2 inches (50 mm) high (see Figure 17).*

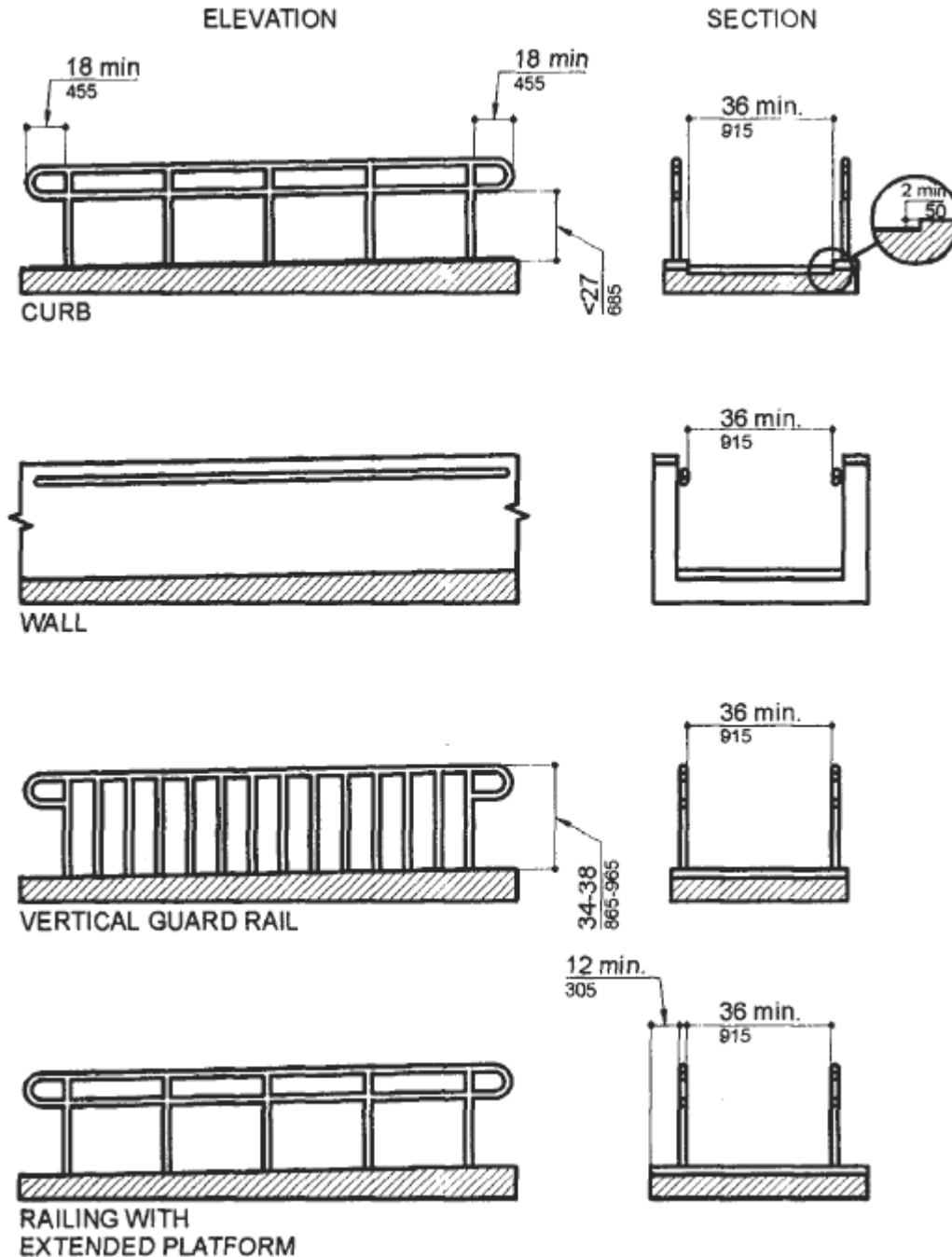

h. **Outdoor conditions-** per Section 11-4.8.8  
*Outdoor ramps and their approaches shall be designed so that water will not accumulate on walking surfaces.*

IV. **Bathrooms and restrooms-** per Section 11-4.1.2(11)  
*If toilet rooms are provided, then each public and common use toilet room shall comply with Section 11-4.22. Other toilet rooms provided for the use of occupants of specific spaces (i.e., a private toilet room for the*

occupant of a private office) shall be adaptable. If bathing rooms are provided, then each public and common use bathroom shall comply with Section 11-4.23. Accessible toilet rooms and bathing facilities shall be on an accessible route.

a. **Doors-** per Section 11-4.22.2

(1) All doors to accessible toilet rooms shall comply with Section 11-4.13. Doors shall not swing into the clear floor space required for any fixture.

*Exception: All new single-family houses, duplexes, triplexes, condominiums, and townhouses shall provide at least one bathroom, located with maximum possible privacy, where bathrooms are provided on habitable grade levels, with a door that has a 29-inch (737 mm) clear opening. However, if only a toilet room is provided at grade level, such toilet room shall have a clear opening of not less than 29 inches (737 mm).*

b. **Restroom- no stalls**

a. **Clear Floor Space-** per Section 11-4.16.2

Clear floor space for water closets not in stalls shall comply with Figure 28. Clear floor space may be arranged to allow either a left-handed or right-handed approach.

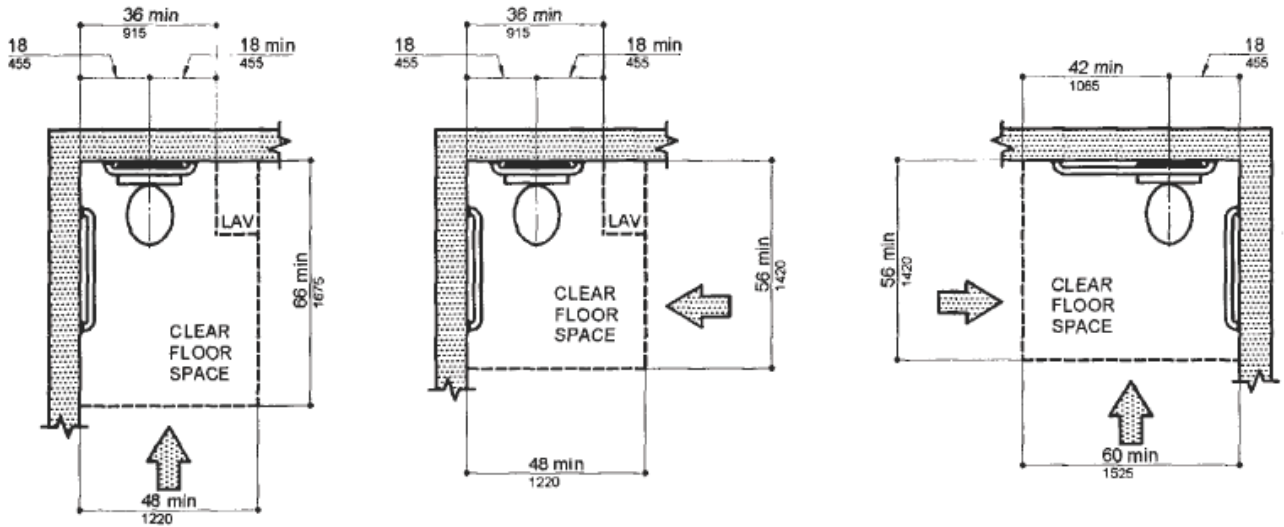

b. **Toilet**

i. **Height-** per Section 11-4.16.3

The height of water closets shall be 17 inches to 19 inches (430 mm to 485mm) measured to the top of the toilet seat [see Figure 29(b)]. Seats shall not be sprung to return to a lifted position.



- ii. **Grab bars-** per Section 11.4.16.4  
*Grab bars for water closets not located in stalls shall comply with Section 11-4.26 and Figure 29. The grab bar behind the water closet shall be 36 inches (915 mm) minimum.*

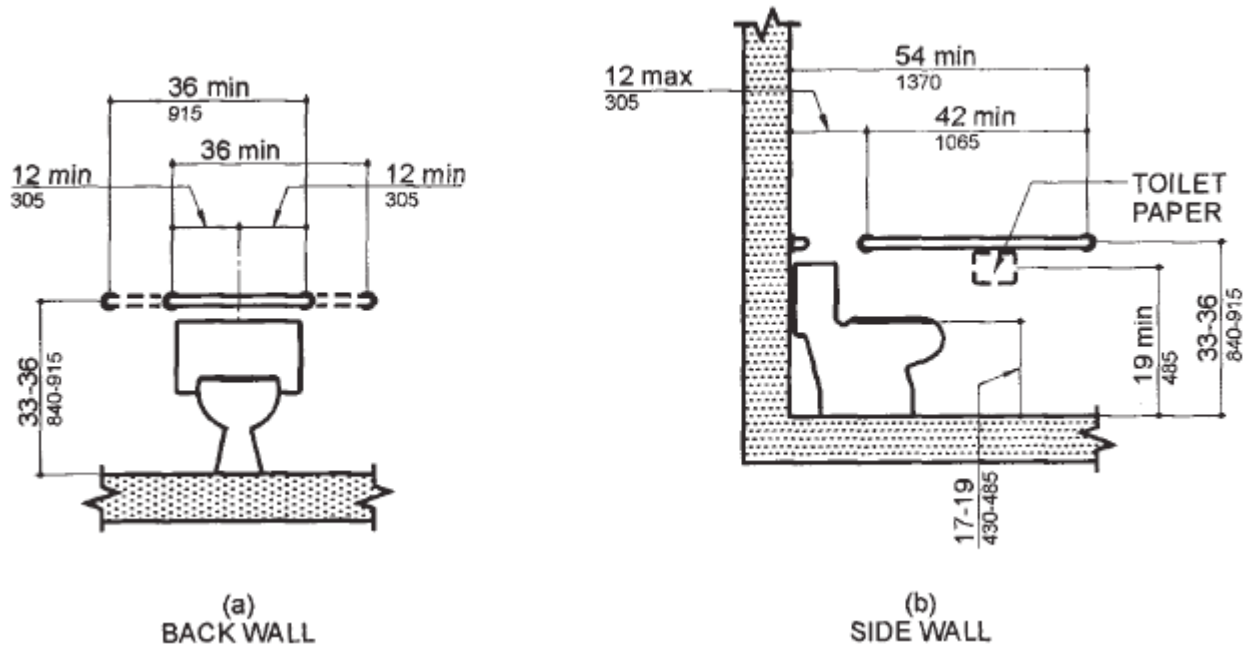

c. **Restroom- with stalls**

a. **Size and arrangement-** per Section 11-4.17.3

*The size and arrangement of the standard toilet stall shall comply with Figure 30(a), Standard Stall. Standard toilet stalls with a minimum depth of 56 inches (1420 mm) [see Figure 30(a)] shall have wall-mounted water closets. If the depth of a standard toilet stall is increased at least 3 inches (76 mm), then a floor-mounted water closet may be used. Arrangements shown for standard toilet stalls may be reversed to allow either a left-or right-hand approach. Additional stalls shall be provided in conformance with Section 11-4.22.4*

*Exception: In instances of alteration work where provision of a standard stall [see Figure 30(a)] is technically infeasible or where plumbing code requirements prevent combining existing stalls to provide space, either alternate stall [see Figure 30(b)] may be provided in lieu of the standard stall.*

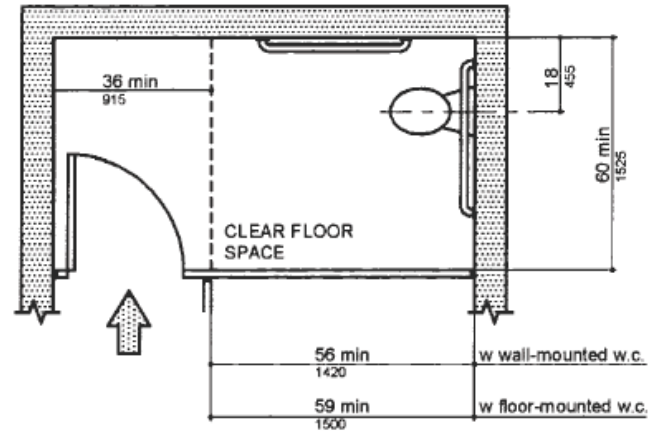
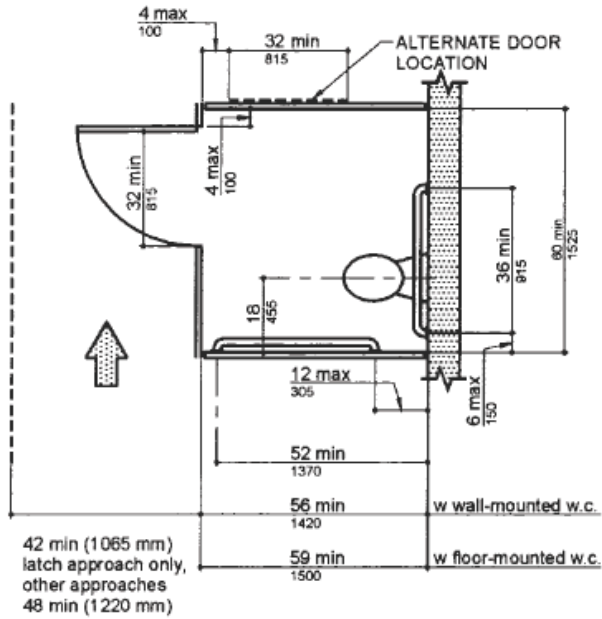

(a)  
Standard Stall

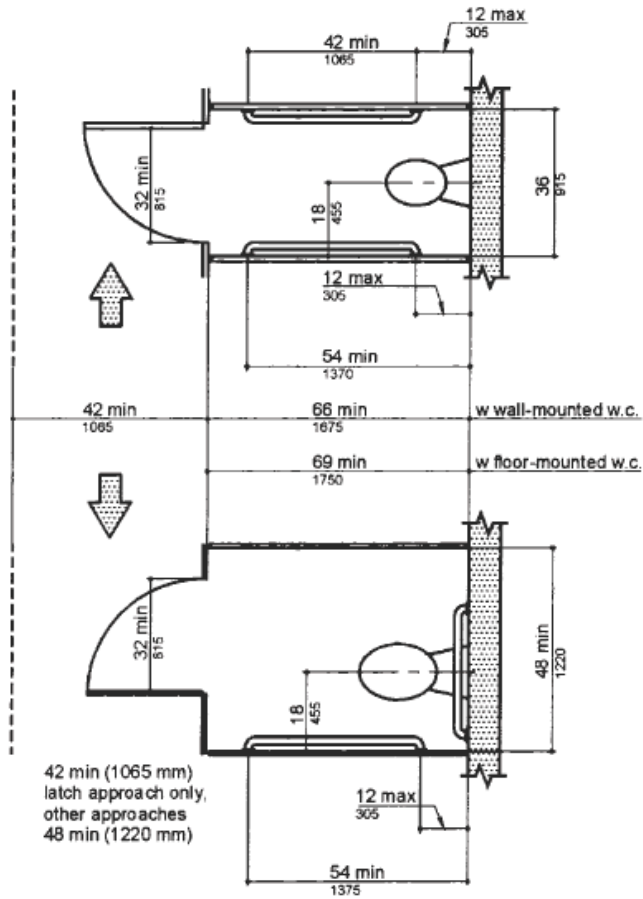

(b)  
Alternate Stalls

b. Toilet

i. **Minimum-** per Section 11-4.22.4

*If toilet stalls are provided, then at least one shall be a standard toilet stall complying with Section 11-4.17; where six or more stalls are provided, in addition to the stall complying with Section 11-4.17.3, at least one stall 36 inches (915 mm) wide with an outward swinging, self-closing door and parallel grab bars complying with Figure 30(d) and Section 11-4.26 shall be provided. Water closets in such stalls shall comply with Section 11-4.16. If water closets are not in stalls, then at least one shall comply with Section 11-4.16.*

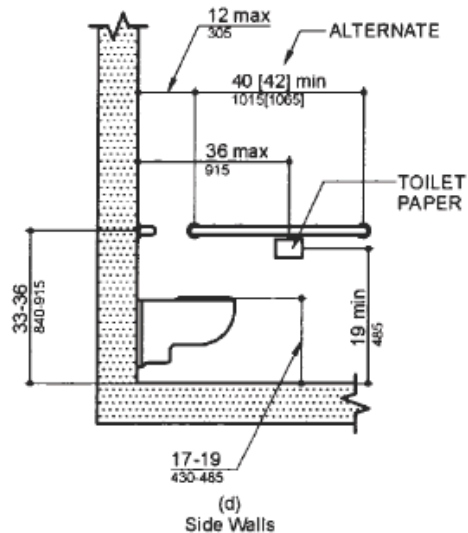

ii. **Height-** per Section 11-4.16.3

*The height of water closets shall be 17 inches to 19 inches (430 mm to 485mm) measured to the top of the toilet seat [see Figure 29(b)]. Seats shall not be sprung to return to a lifted position.*

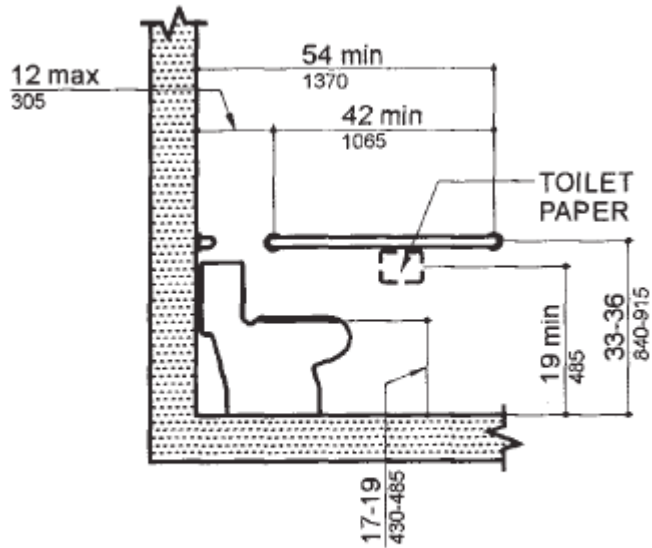

(b)  
SIDE WALL

- iii. **Grab bars-** per Section 11-4.17.6  
*Grab bars complying with the length and positioning shown in Figures 30(a), 30(b), 30(c), and 30(d) shall be provided. Grab bars may be mounted with any desired method as long as they have a gripping surface at the locations shown and do not obstruct the required clear floor area. Grab bars shall comply with Section 11-4.26.*

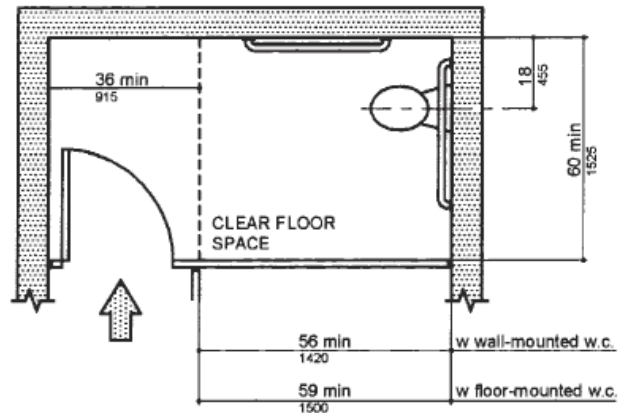
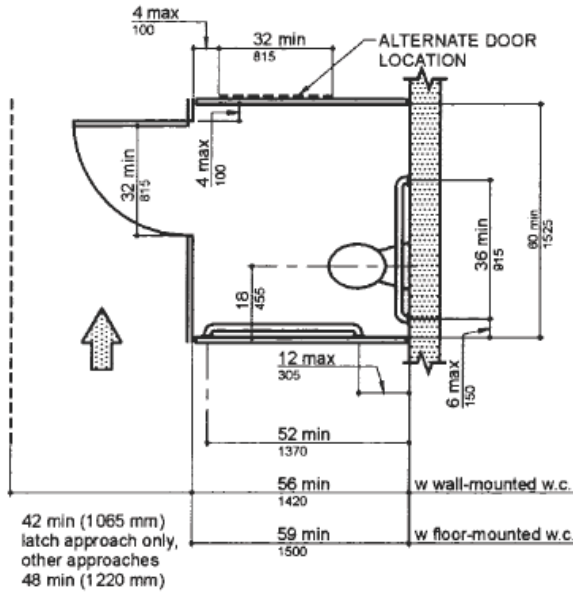

(a) Standard Stall

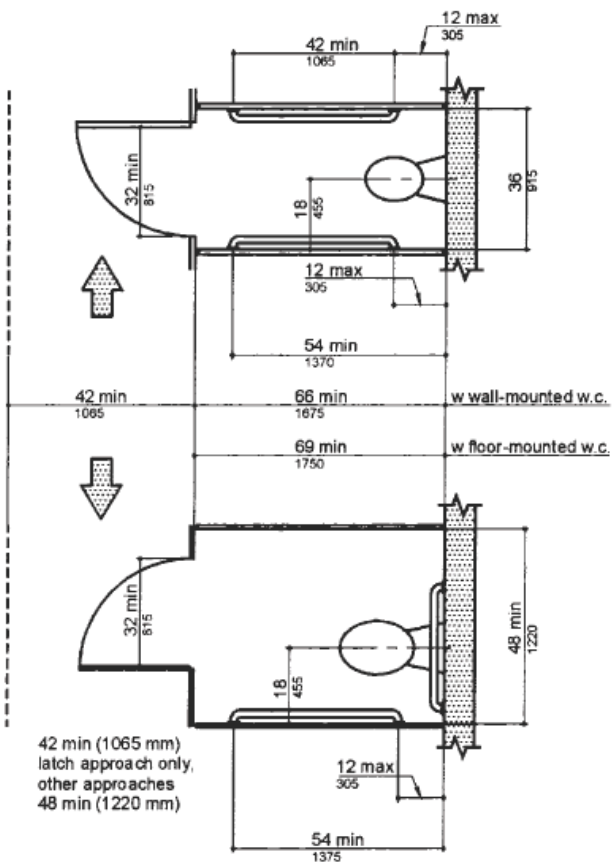

(b) Alternate Stalls

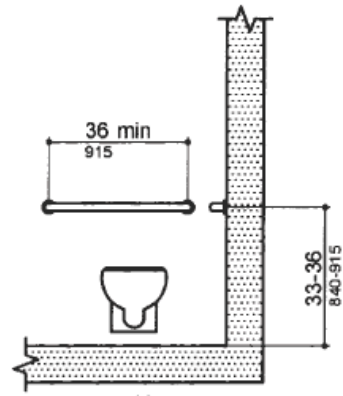

(c) Rear Wall of Standard Stall

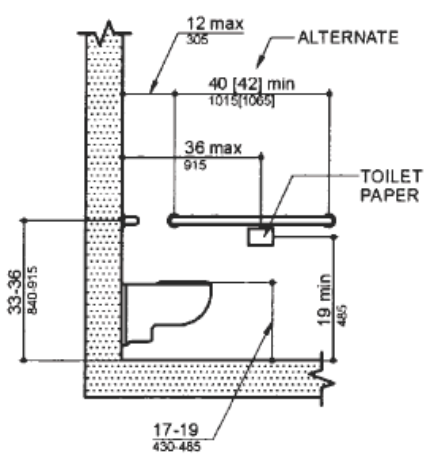

(d) Side Walls

d. Urinals

a. Minimum- per Section 11-4.22.5

*If urinals are provided, then at least one shall comply with Section 11-4.18.*

**b. Height-** per Section 11-4.18.2

*Urinals shall be stall-type or wall-hung with an elongated rim at a maximum of 17 inches (430 mm) above the finish floor.*

**c. Clear floor space-** per Section 11-4.18.3

*A clear floor space 30 inches by 48 inches (760 mm by 1220 mm) shall be provided in front of urinals to allow forward approach. This clear space shall adjoin or overlap an accessible route and shall comply with Section 11-4.2.4. Urinal shields that do not extend beyond the front edge of the urinal rim may be provided with 29 inches (735 mm) clearance between them.*

**e. Lavatories and mirrors**

**a. Minimums-** per Section 11-4.22.6

*If lavatories and mirrors are provided, then at least one of each shall comply with Section 11-4.19.*

**b. Height and clearances-** per Section 11-4.19.2

*Lavatories shall be mounted with the rim or counter surface no higher than 34 inches (865 mm) above the finish floor. Provide a clearance of at least 29 inches (735 mm) above the finish floor to the bottom of the apron. Knee and toe clearance shall comply with Figure 31.*

**c. Clear floor space-** per Section 11-4.19.3

*A clear floor space 30 inches by 48 inches (760 mm by 1219 mm) complying with Section 11-4.2.4 shall be provided in front of a lavatory to allow forward approach. Such clear floor space shall adjoin or overlap an accessible route and shall extend a maximum of 19 inches (485 mm) underneath the lavatory (see Figure 32).*

**d. Exposed pipes are surfaces-** per Section 11-4.19.4

*Hot water and drain pipes under lavatories shall be insulated or otherwise configured to protect against contact. There shall be no sharp or abrasive surfaces under lavatories.*

**e. Mirrors-** per Section 11-4.19.6

*Mirrors shall be mounted with the bottom edge of the reflecting surface no higher than 40*

inches (1015 mm) above the finish floor  
(see Figure 31).

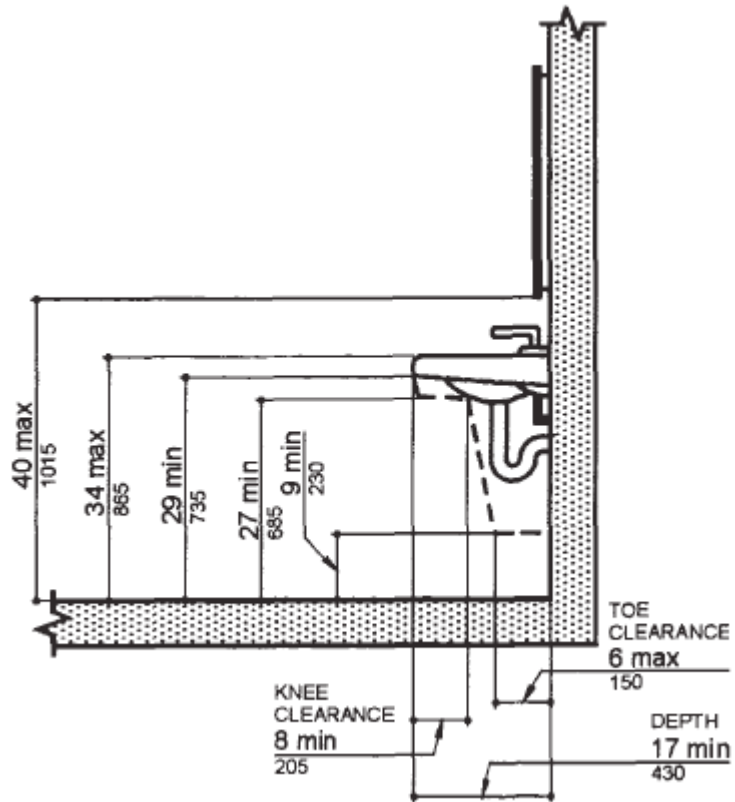

f. **Sinks**

- i. **Height-** per Section 11-4.24.2  
*Sinks shall be mounted with the counter or rim no higher than 34 inches (865 mm) above the finish floor.*
- ii. **Knee clearance-** per Section 11-4.24.3  
*Knee clearance that is at least 27 inches (685 mm) high, 30 inches (760 mm) wide, and 19 inches (485 mm) deep shall be provided underneath sinks.*
- iii. **Depth-** per Section 11-4.24.4  
*Each sink shall be a maximum of 6<sup>1</sup>/<sub>2</sub> inches (165 mm) deep.*
- iv. **Clear floor space-** per Section 11-4.24.5  
*A clear floor space at least 30 inches by 48 inches (760 mm by 1219 mm) complying with Section 11-4.2.4 shall be provided in front of a sink to allow forward approach. The clear floor space shall be on an accessible route and shall extend a*

maximum of 19 inches (485 mm) underneath the sink (see Figure 32).

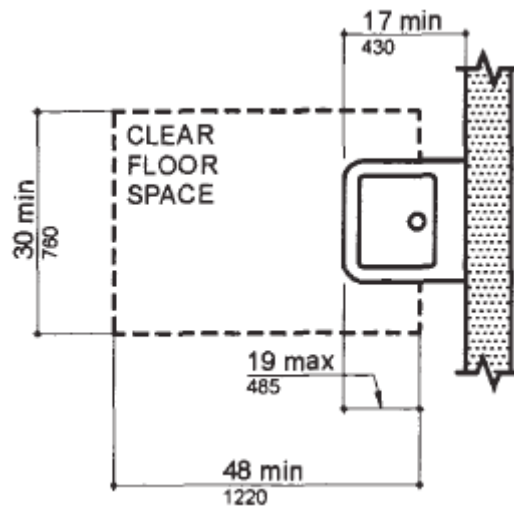

f. **Shower Facilities**

a. **Minimums-** per Section 11-4.23.8

*If tubs or showers are provided, then at least one accessible tub that complies with Section 11-4.20 or at least one accessible shower that complies with Section 11-4.21 shall be provided.*

b. **Bathtubs**

i. **Floor space-** per Section 11-4.20.2

*Clear floor space in front of bathtubs shall be as shown in Figure 33.*

ii. **Seat-** per Section 11-4.20.3

*An in-tub seat or a seat at the head end of the tub shall be provided as shown in Figure 33 and Figure 34. The structural strength of seats and their attachments shall comply with Section 11-4.26.3. Seats shall be mounted securely and shall not slip during use.*

iii. **Grab bars-** per Section 11-4.20.4

*Grab bars complying with Section 11-4.26 shall be provided as shown in Figure 33 and Figure 34.*



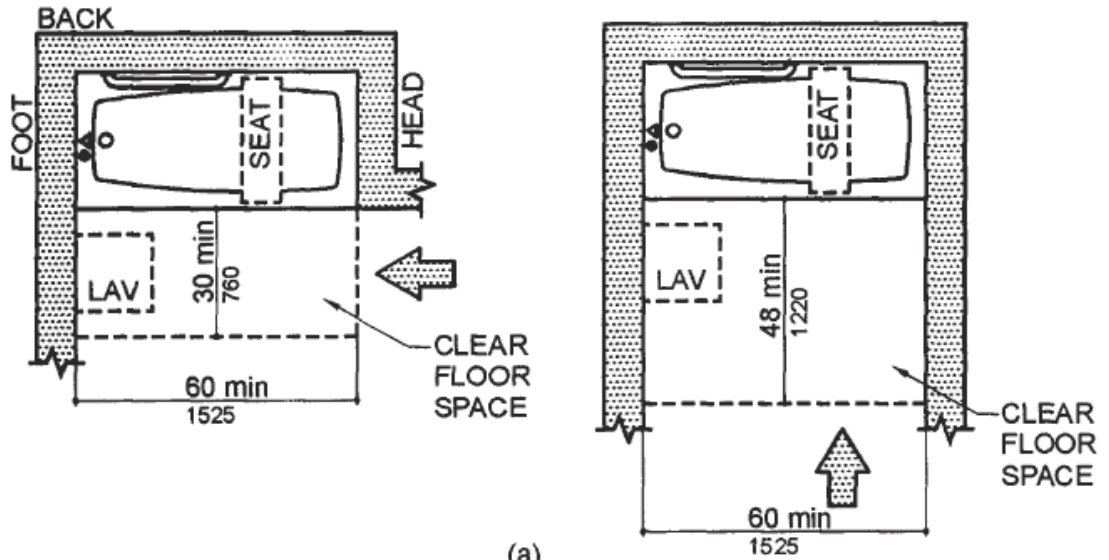

(a)  
With Seat in Tub

**SYMBOL KEYS:**

- = Shower controls
- ◀ = Shower head
- = Drain

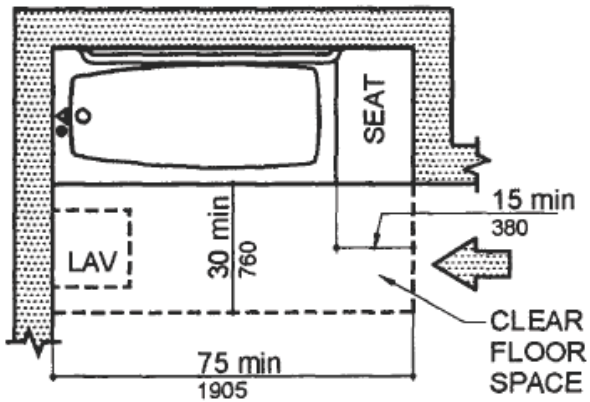

(b)  
With Seat at Head of Tub

- iv. **Controls-** per Section 11-4.20.5  
*Faucets and other controls complying with Section 11-4.27.4 shall be located as shown in Figure 34.*

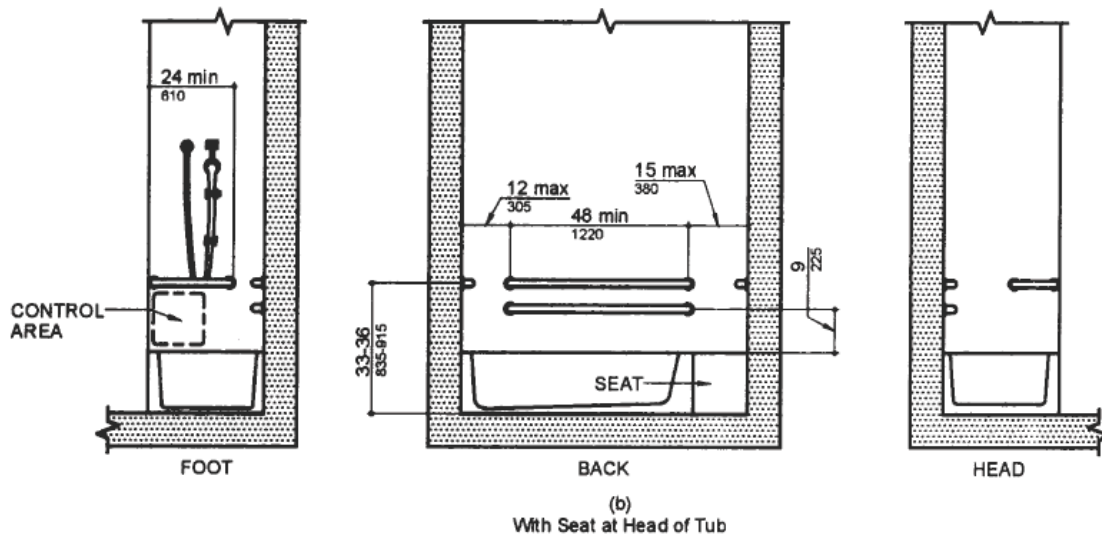
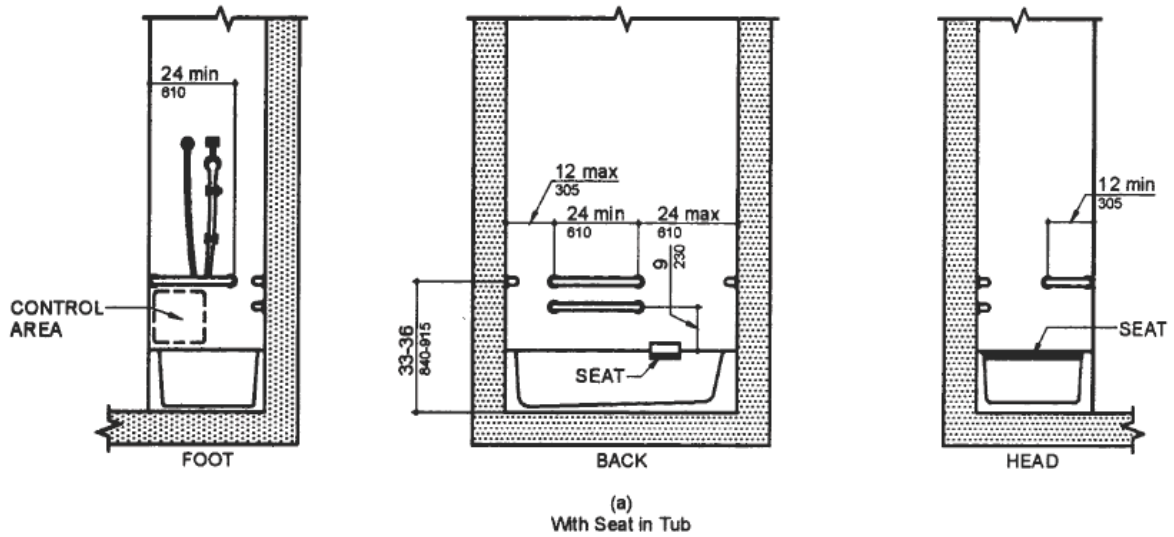

- v. **Shower unit-** per Section 11-4.20.6  
*A shower spray unit with a hose at least 60 inches (1525 mm) long that can be used both as a fixed shower head and as a hand-held shower shall be provided.*
- vi. **Bathtub enclosures-** per Section 11-4.20.7  
*If provided, enclosures for bathtubs shall not obstruct controls or transfer from wheelchairs onto bathtub seats or into tubs. Enclosures on*

bathtubs shall not have tracks mounted on their rims.

c. Shower Stalls

- i. **Size and clearances-** per Section 11-4.21.2

*Except as specified in Section 11-9.1.2, shower stall size and clear floor space shall comply with Figure 35(a) or Figure 35(b). The shower stall in Figure 35(a) shall be 36 inches by 36 inches (915 mm by 915 mm). Shower stalls required by Section 11-9.1.2 shall comply with Figure 57(a) or Figure 57(b). The shower stall in Figure 35(b) will fit into the space required for a bathtub.*

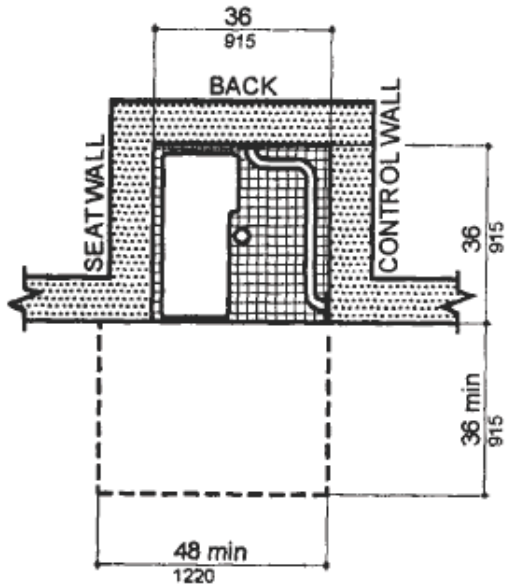

(a)  
36-in. by 36-in.  
(915-mm by 915-mm) Stall

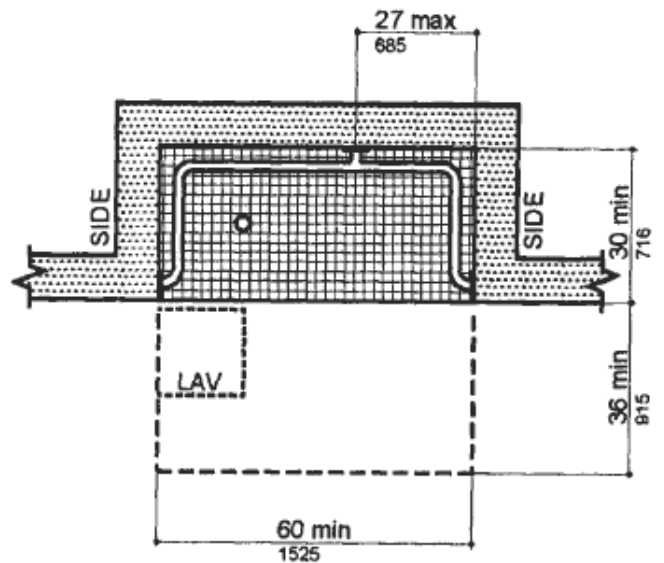

(b)  
30-in. by 60-in.  
(760-mm by 1525-mm) Stall

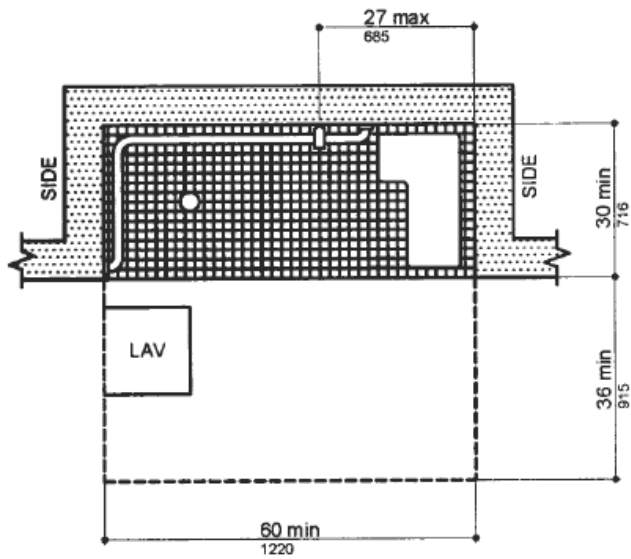

(a)

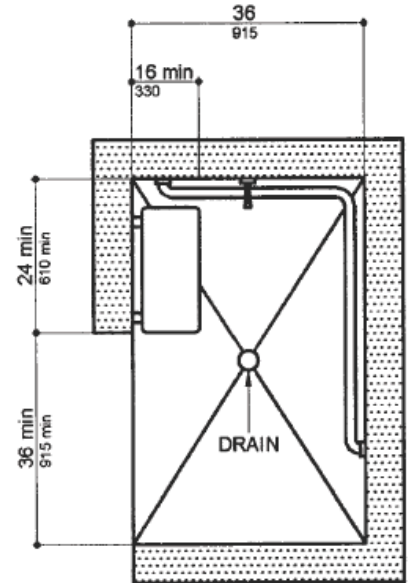

(b)

ii. **Seat-** per Section 11-4.21.3

*A seat shall be provided in shower stalls 36 inches by 36 inches (915 mm by 915 mm) and shall be as shown in Figure 36. The seat shall be mounted 17 inches to 19 inches (430 mm to 485 mm) from the bathroom floor and shall extend the full depth of the stall. In a 36-inch by 36-inch (915 mm by 915 mm) shower stall, the seat shall be on the wall opposite the controls. Where a fixed seat is provided in a 30-inch by 60-inch minimum (760 mm by 1525 mm) shower stall, it shall be a folding type and shall be mounted on the wall adjacent to the controls as shown in Figure 57. The structural strength of seats and their attachments shall comply with Section 11-4.26.3.*

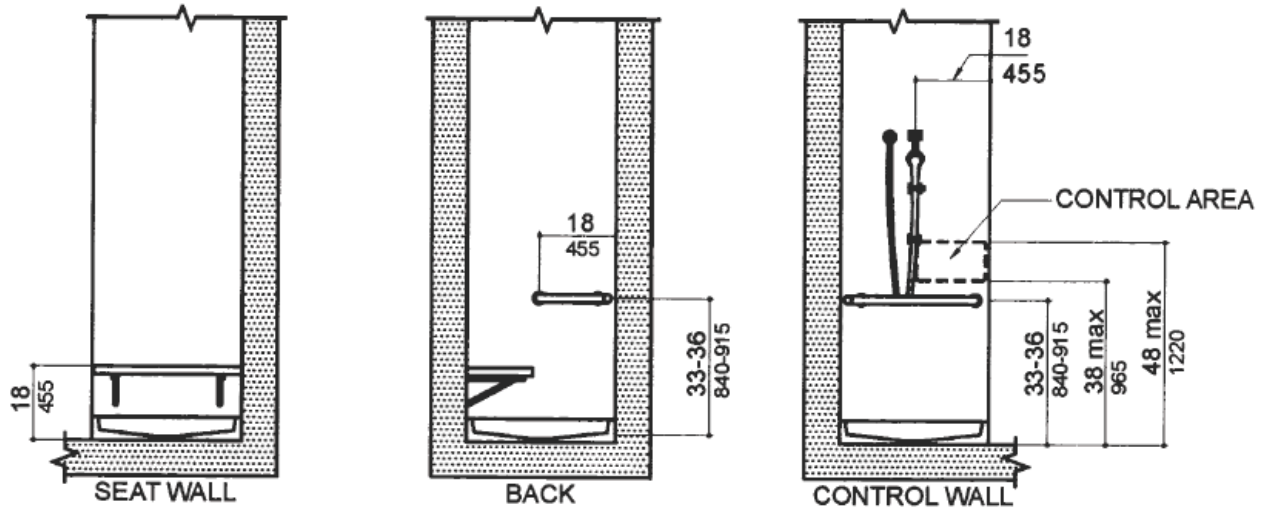

(a)

36-in by 36-in (915-mm by 915-mm) Stall

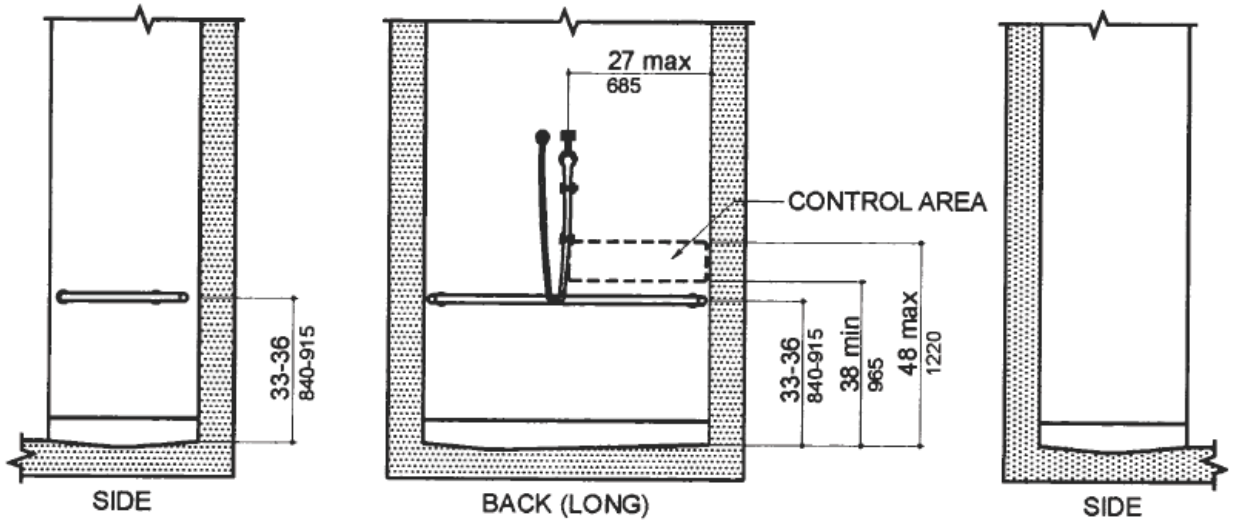

(b)

30-in by 60-in (760-mm by 1525-mm) Stall

NOTE: Shower head and control area may be on back (long) wall (as shown) or on either side wall.

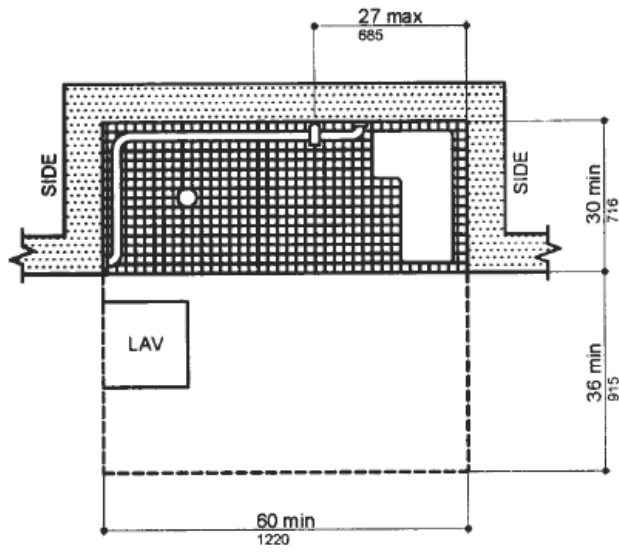

(a)

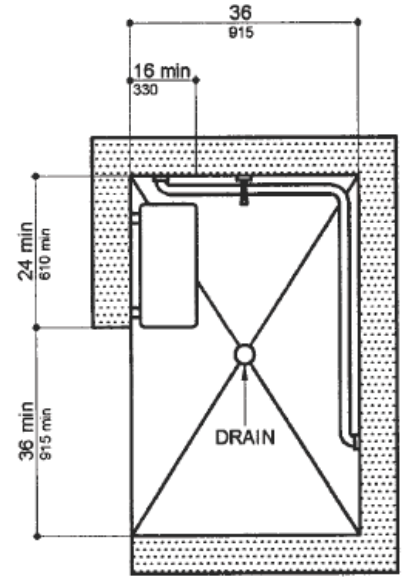

(b)

- iii. **Grab bars-** per Section 11-4.21.4  
*Grab bars complying with Section 11-4.26 shall be provided as shown in Figure 37.*

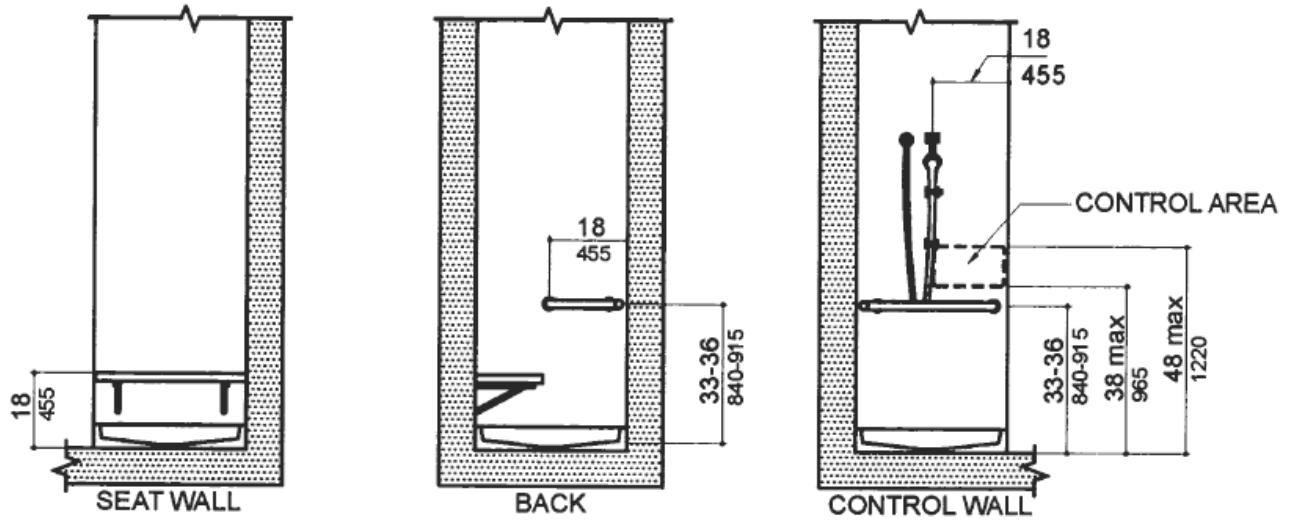

(a)  
36-in by 36-in (915-mm by 915-mm) Stall

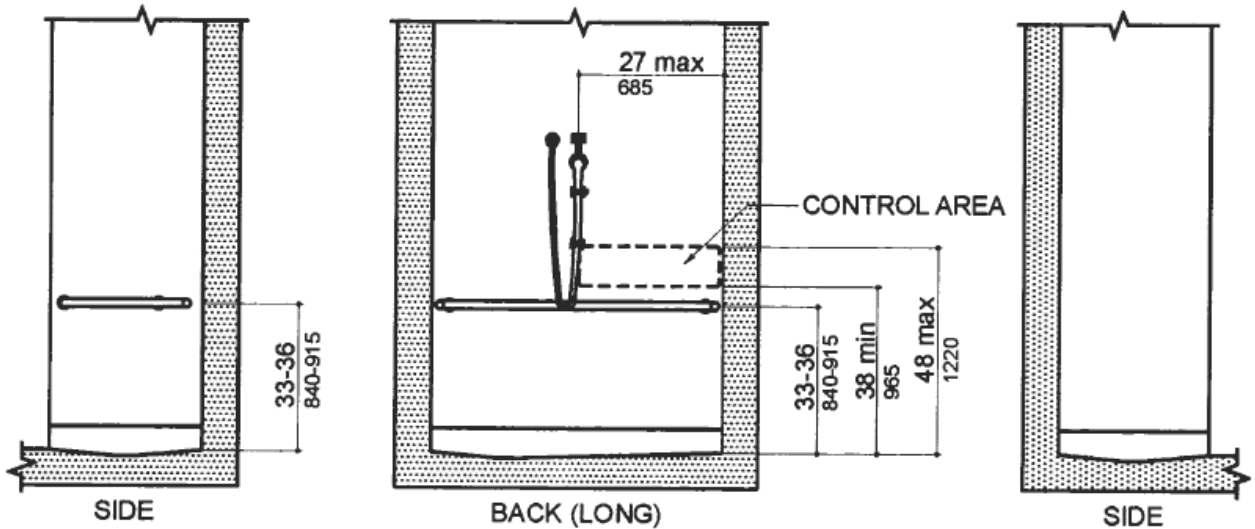

(b)  
30-in by 60-in (760-mm by 1525-mm) Stall

NOTE: Shower head and control area may be on back (long) wall (as shown) or on either side wall.

i. **Size and spacing-** per Section 11-4.26.2

*The diameter or width of the gripping surfaces of a handrail or grab bar shall be 1<sup>1</sup>/<sub>4</sub> inches to 1<sup>1</sup>/<sub>2</sub> inches (32 mm to 38 mm), or the shape shall provide an equivalent gripping surface. If handrails or grab bars are mounted adjacent to a wall, the space between the wall and the grab bar shall be 1<sup>1</sup>/<sub>2</sub>*

*inches (38 mm) [see Figure 39(a), Figure 39(b), Figure 39(c), and Figure 39(e)]. Handrails may be located in a recess if the recess is a maximum of 3 inches (76 mm) deep and extends at least 18 inches (455 mm) above the top of the rail [see Figure 39(d)].*



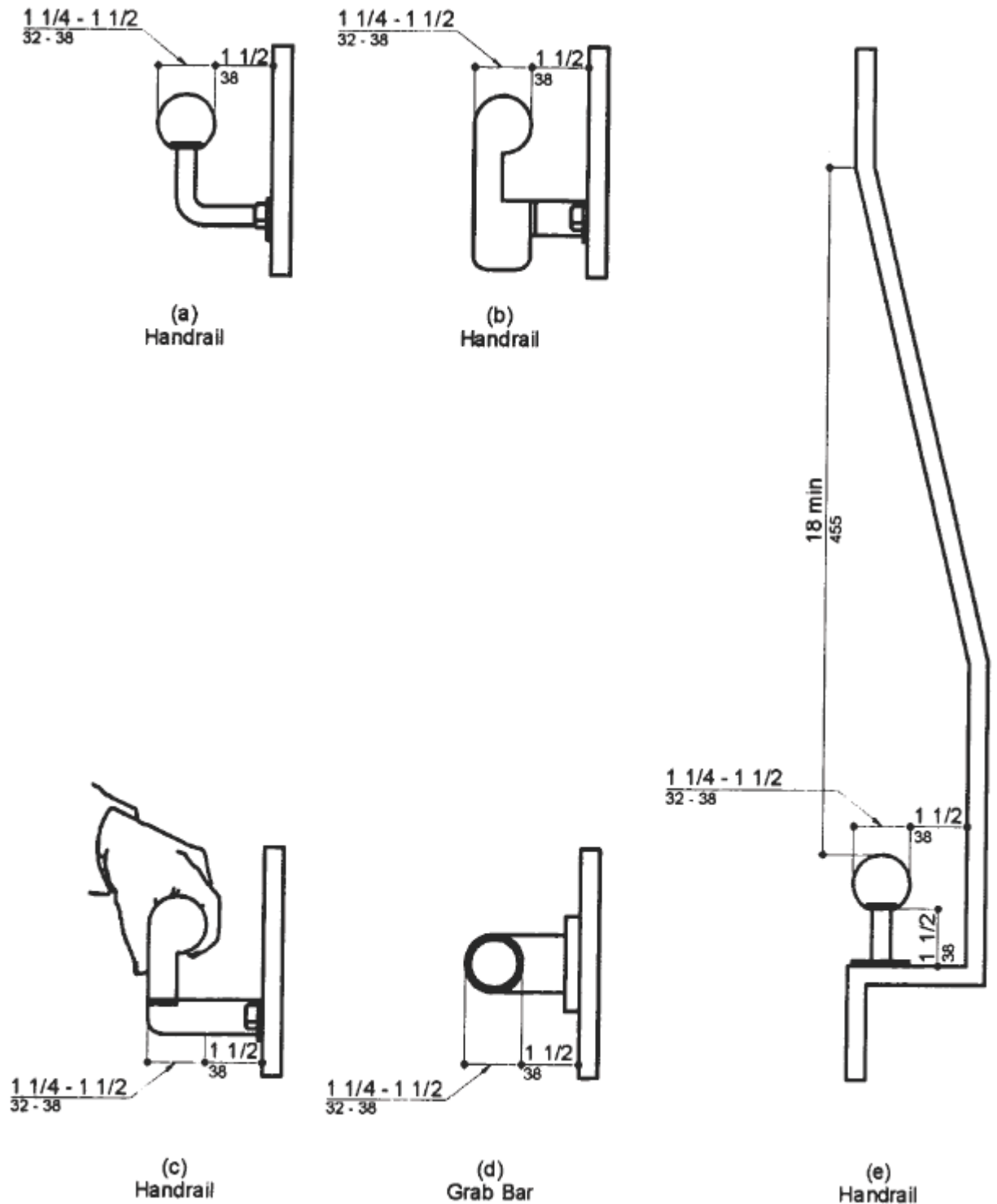

iv. **Controls-** per Section 11-4.21.5  
*Faucets and other controls complying with Section 11-4.27.4 shall be located as shown in Figure 37. In shower stalls 36 inches by 36 inches (915 mm by 915 mm), all controls,*

faucets, and the shower unit shall be mounted on the side wall opposite the seat.

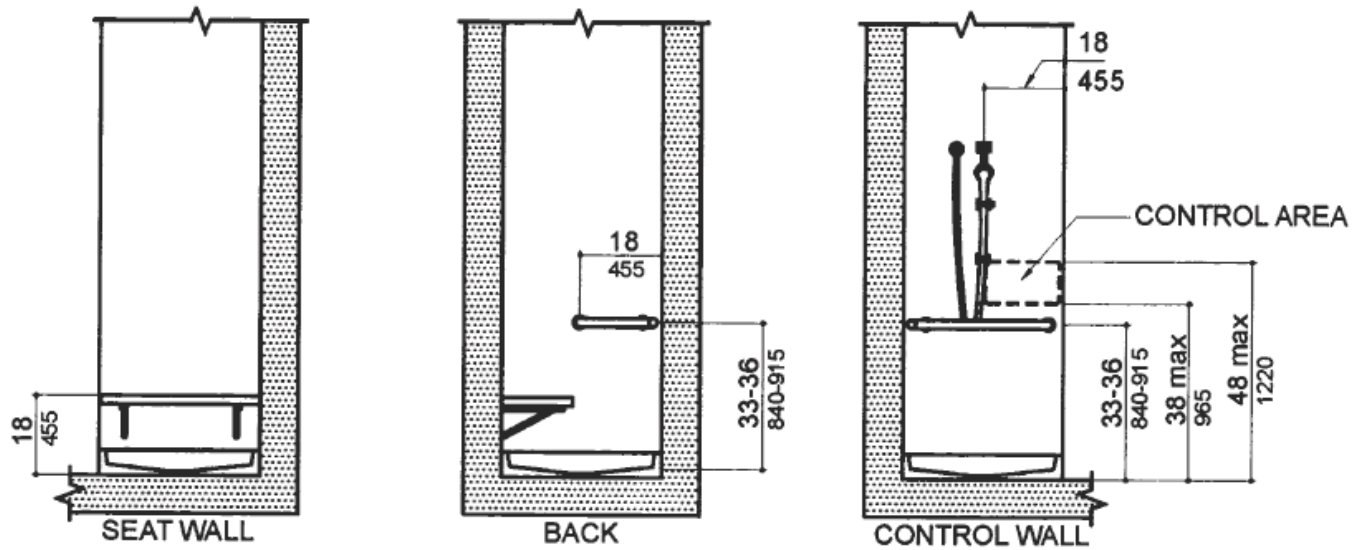

(a)  
36-in by 36-in (915-mm by 915-mm) Stall

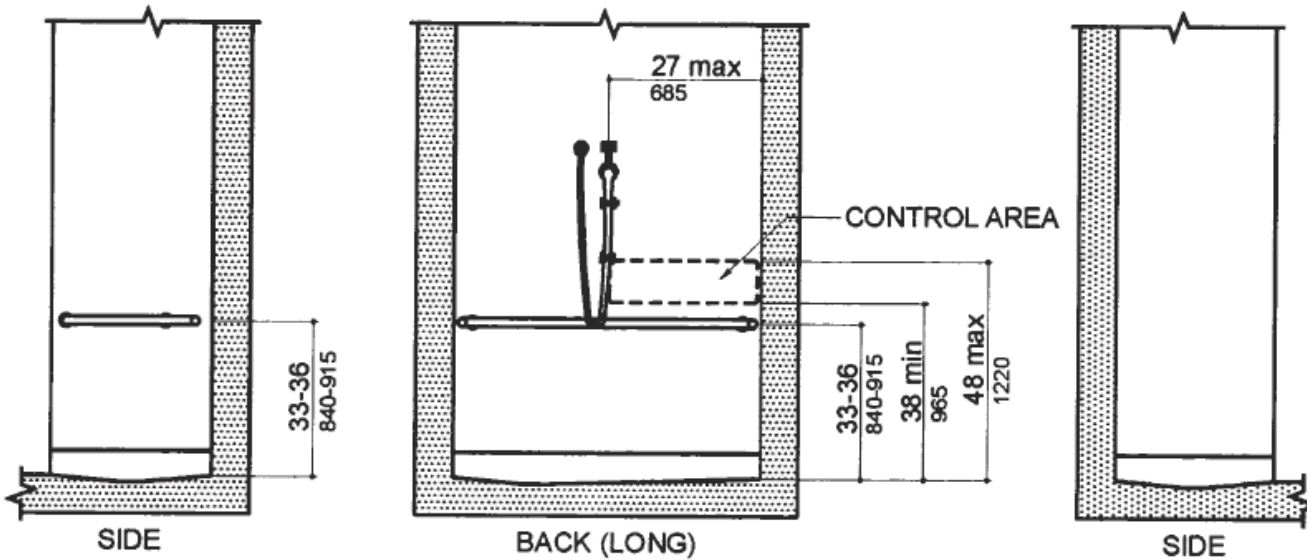

(b)  
30-in by 60-in (760-mm by 1525-mm) Stall

NOTE: Shower head and control area may be on back (long) wall (as shown) or on either side wall.

- v. **Shower unit-** per Section 11-4.21.6  
A shower spray unit with a hose at least 60 inches (1525 mm) long that can be used both as a fixed shower head and as a hand-held shower shall be provided.

*Exception: In unmonitored facilities where vandalism is a consideration, a fixed shower head mounted at 48 inches (1220 mm) above the shower floor may be used in lieu of a hand-held shower head.*

- vi. **Curbs-** per Section 11-4.21.7  
*If provided, curbs in shower stalls 36 inches by 36 inches (915 mm by 915 mm) shall be no higher than 1/2 inch (13 mm). Shower stalls that are 30 inches by 60 inches (760 mm by 1525 mm) minimum shall not have curbs.*
- vii. **Shower enclosures-** per Section 11-4.21.8  
*If provided, enclosures for shower stalls shall not obstruct controls or obstruct transfer from wheelchairs onto shower seats.*

**6. Plumbing Code-** per FBC-P

- I. **Minimum number of required plumbing fixtures-** per Section 403 and table 403.1
  - a. **Toilets**
  - b. **Urinals**
  - c. **Sinks**
  - d. **Bathtubs/ Showers**
  - e. **Other**

*403.1 Minimum number of fixtures. Plumbing fixtures shall be provided for the type of occupancy and in the minimum number shown in Table 403.1. Types of occupancies not shown in Table 403.1 shall be considered individually by the code official. The number of occupants shall be determined by the Florida Building Code, Building. Occupancy classification shall be determined in accordance with the Florida Building Code, Building.*

*403.1.1 Potty parity. In assembly occupancies, restrooms which are open to the public must have a ratio of 3:2 water closets provided for women as the combined total of water closets and urinals provided for men, unless these are two or fewer such fixtures for men, in accordance with §553.86, Florida Statutes.*

*Exception: This section does not apply to establishments licensed under Chapter*

*509, Florida Statutes, if the establishment does not provide meeting or banquet rooms which accommodate more than 150 people, and the establishment has at least the same number of water closets for women as the combined total of water closets and urinals for men.*

*403.1.1.1 Definitions.*

- 1. New construction. Means new construction, building, alteration, rehabilitation or repair that equals or exceeds 50 percent of the replacement value existing on October 1, 1992, unless the same was under design or construction, or under construction contract before October 1, 1992.*
- 2. Assembly occupancy. The use of a building or structure, or any portion thereof, for the gathering together of people for purposes such as civic, social or religious functions or for recreation, or for food or drink consumption, or awaiting transportation.*
- 3. Historic building. A building which is (a) listed on the National Register of Historic Places; (b) listed on the State Register of Historic Places; (c) listed on a municipal register of historic property, designated according to local ordinance; or (d) included in a district which is listed on a municipal, state or national register of historic property and which has been determined to contribute to the historic significance of the district.*

*403.1.1.2 Occupancy content calculation.*

*The occupancy content of a building, which determines the number of*

*water closets required for men, shall be calculated using the square footage per person requirements established by the Florida Building Code, Building.*

*403.1.2 Unisex toilet and bath fixtures. Fixtures located within unisex toilet and bathing rooms complying with Section 403.7 shall be included in determining the minimum required number of fixtures for assembly and mercantile occupancies.*

*403.1.3 For the purposes of calculating the minimum number of required plumbing facilities, the requirements of Table 403.1 shall apply to any areas outside of the building that are used as part of the building's designated occupancy (single or mixed). Where additional seating is also utilized in these areas, the actual number of seats shall be added to the number of persons calculated by Table 403.1 to obtain the total additional facilities required.*

*403.2 Separate facilities. Where plumbing fixtures are required, separate facilities shall be provided for each sex.*

*Exceptions:*

- 1. Separate facilities shall not be required for dwelling units and sleeping units.*
- 2. Separate facilities shall not be required for food service establishments which seat 10 persons or less.*
- 3. Separate facilities shall not be required in business and mercantile occupancies with a total floor area of 3,000 square feet (279 m<sup>2</sup>) or less.*

*403.3 Number of occupants of each sex. The required water closets, lavatories, and showers or bathtubs shall be distributed equally between the sexes based on the percentage of each sex anticipated in the occupant load. The occupant load shall be composed of 50 percent of each sex, unless statistical data approved by the code official indicate a different distribution of the sexes (see also Section 403.1.1).*

*403.4 Required public toilet facilities. Customers, patrons and visitors shall be provided with public toilet*

*facilities in structures and tenant spaces intended for public utilization. The accessible route to public facilities shall not pass through kitchens, storage rooms, closets or similar spaces. Employees shall be provided with toilet facilities in all occupancies. Employee toilet facilities shall be either separate or combined employee and public toilet facilities.*

*403.4.1 Location of toilet facilities in occupancies other than covered malls. In occupancies other than covered malls, the required public and employee toilet facilities shall be located not more than one story above or below the space required to be provided with toilet facilities, and the path of travel to such facilities shall not exceed a distance of 500 feet (152 m).*

*Exception: The location and maximum travel distances to required employee facilities in factory and industrial occupancies are permitted to exceed that required by this section, provided that the location and maximum travel distance are approved.*

*403.4.2 Location of toilet facilities in covered malls. In covered mall buildings, the required public and employee toilet facilities shall be located not more than one story above or below the space required to be provided with toilet facilities, and the path of travel to such facilities shall not exceed a distance of 300 feet (91 440 mm). In covered mall buildings, the required facilities shall be based on total square footage, and facilities shall be installed in each individual store or in a central toilet area located in accordance with this section. The maximum travel distance to central toilet facilities in covered mall buildings shall be measured from the main entrance of any store or tenant space. In covered mall buildings, where employees' toilet facilities are not provided in the individual store, the maximum travel distance shall be measured from the employee's work area of the store or tenant space.*

*403.4.3 Pay facilities. Where pay facilities are installed, such facilities shall be in excess of the required minimum facilities. Required facilities shall be free of charge.*

*403.5 Signage. Required public facilities shall be designated by a legible sign for each sex. Signs shall be readily visible and located near the entrance to each toilet facility.*

*403.6 Reserved.*

*403.7 Unisex toilet and bathing rooms. In assembly and mercantile occupancies, an accessible unisex toilet room shall be provided where an aggregate of six or more male and female water closets is required. In buildings of mixed occupancy, only those water closets required for the assembly or mercantile occupancy shall be used to determine the unisex toilet room requirement. In recreational facilities where separate-sex bathing rooms are provided, an accessible unisex bathing room shall be provided. Fixtures located within unisex toilet and bathing rooms shall be included in determining the number of fixtures provided in an occupancy.*

*Exception: Where each separate-sex bathing room has only one shower or bathtub fixture, a unisex bathing room is not required.*

*403.7.1 Required fixtures. Unisex toilet and bathing rooms shall comply with Sections 403.7.2 through 403.7.7.*

*403.7.2 Unisex toilet rooms. Unisex toilet rooms shall include only one water closet and only one lavatory. A unisex bathing room in accordance with Section 403.7.3 shall be considered a unisex toilet room.*

*Exception: A urinal is permitted to be provided in addition to the water closet in a unisex toilet room.*

*403.7.3 Unisex bathing rooms. Unisex bathing rooms shall include only one shower or bathtub fixture. Unisex bathing rooms shall also include one water closet and one lavatory. Where storage facilities are provided for separate-sex bathing rooms, accessible storage facilities shall be provided for unisex bathing rooms.*

*403.7.4 Location. Unisex toilet and bathing rooms shall be located on an accessible route. Unisex toilet rooms shall be located not more than one story above or below separate-sex toilet rooms. The accessible route from any separate-sex toilet room to a unisex toilet room shall not exceed 500 feet (152 m).*

*403.7.5 Prohibited location. In passenger transportation facilities and airports, the accessible route from separate-sex toilet rooms to a unisex toilet room shall not pass through security checkpoints.*

*403.7.6 Clear floor space. Where doors swing into a unisex toilet or bathing room, a clear floor space not less than 30 inches by 48 inches (762 mm by 1219 mm) shall be provided, within the room, beyond the area of the door swing.*

*403.7.7 Privacy. Doors to unisex toilet and bathing rooms shall be securable from within the room.*

*403.8 Sanitary facilities for public swimming pools. Separate sanitary facilities shall be provided and labeled for each sex and shall be located within a 200 foot radius of the nearest water's edge of each pool served by the facilities.*

*Exception: Where a swimming pool serves only a designated group of residential dwelling units and not the general public, poolside sanitary facilities are not required if all living units are within a 200 foot radius of the nearest water's edge, are not over three stories in height and are each equipped with private sanitary facilities.*

*403.8.1 Required fixtures. Fixtures shall be provided as indicated on Table 403.8. An additional set of fixtures shall be provided in the men's restroom for every 5000 square feet or major fraction thereof for pools greater than 10,000 square feet. Women's restrooms shall have a ratio of three to two water closets provided for women as the combined total of water closets and urinals provided for men.*

*403.8.2 Outside access. Outside access to facilities shall be provided for bathers at*



*outdoor pools. If they are not visible from any portion of the pool deck, signs shall be posed showing directions to the facilities. Directions shall be legible from any portion of the pool deck; letters shall be a minimum of 1-inch high.*

*403.8.3 Sanitary facility floors. Floors of sanitary facilities shall be constructed of concrete or other nonabsorbent materials, shall have a smooth, slip-resistant finish, and shall slope to floor drains. Carpets, duckboards and footbaths are prohibited. The intersection between the floor and walls shall be covered.*

**Table 403.1**

NO.	CLASS.	OCC.	DESCRIP.	WATER CLOSETS (URINALS SEE SECTION 419.2)		LAVATORIES		BATHTUBS/SHOWERS	DRINKING FOUNTAIN (SEE SECTION 410.1)	OTHER
				M	F	M	F			
1	Assembly (see Sections 403.2, 403.4 and 403.4.1)	A-1 <sup>d</sup>	Theaters and other buildings for the performing arts and motion pictures	1 per 125	1 per 65	1 per 200		$\frac{3}{4}$	1 per 500	1 service sink
		A-2 <sup>d</sup>	Nightclubs, bars, taverns, dance halls and buildings for similar purposes	1 per 40	1 per 40	1 per 75		$\frac{3}{4}$	1 per 500	1 service sink
			Restaurants, banquet halls and food courts	1 per 75	1 per 75	1 per 200		$\frac{3}{4}$	1 per 500	1 service sink
		A-3 <sup>d</sup>	Auditoriums without permanent seating, art galleries, exhibition halls, museums, lecture halls, libraries, arcades	1 per 125	1 per 65	1 per 200		$\frac{3}{4}$	1 per 500	1 service sink

			and gymnasiums						
			Passenger terminals and transportation facilities	1 per 500	1 per 500	1 per 750	$\frac{3}{4}$	1 per 1,000	1 service sink
			Places of worship and other religious services.	1 per 150	1 per 75	1 per 200	$\frac{3}{4}$	1 per 1,000	1 service sink

NO.	CLASS.	OCC.	DESCRIP.	WATER CLOSETS (URINALS SEE SECTION 419.2)		LAVATORIES		BATHTUBS/SHOWERS	DRINKING FOUNTAIN (SEE SECTION 410.1)	OTHER
				M	F	M	F			
		A-4	Coliseums, arenas, skating rinks, pools and tennis courts for indoor sporting events and activities	1 per 75 for the first 1,500 and 1 per 120 for the remainder exceeding 1,500	1 per 40 for the first 1,500 and 1 per 60 for the remainder exceeding 1,500	1 per 200	1 per 150	$\frac{3}{4}$	1 per 1,000	1 service sink
		A-5	Stadiums, amusement parks, bleachers and grandstands for outdoor sporting events and activities	1 per 75 for the first 1,500 and 1 per 120 for the remainder exceeding 1,500	1 per 40 for the first 1,500 and 1 per 60 for the remainder exceeding 1,500	1 per 200	1 per 150	$\frac{3}{4}$	1 per 1,000	1 service sink
2	Business (see Sections 403.2, 403.4 and 403.4.1)	B	Buildings for the transaction of business, professional services, other services involving	1 per 25 for the first 50 and 1 per 50 for the remainder exceeding 50		1 per 40 for the first 80 and 1 per 80 for the remainder exceeding 80		$\frac{3}{4}$	1 per 100	-

			merchandise, office buildings, banks, light industrial and similar uses					
3	Educational	E/D	Educational facilities/Day care (313, FBC-B)	1 per 50	1 per 50	$\frac{3}{4}$	1 per 100	1 service sink
4	Factory and industrial	F-1 and F-2	Structures in which occupants are engaged in work fabricating, assembly or processing of products or materials	1 per 100	1 per 100	(see Section 411)	1 per 400	1 service sink
5	Institutional	I-1	Residential care	1 per 10	1 per 10	1 per 8	1 per 100	1 service sink
		I-2	Hospitals, ambulatory nursing home patients <sup>b</sup>	1 per room <sup>c</sup>	1 per room <sup>c</sup>	1 per 15	1 per 100	1 service sink per floor
			Employees, other than residential care <sup>b</sup>	1 per 25	1 per 35	$\frac{3}{4}$	1 per 100	$\frac{3}{4}$
			Visitors, other than residential care	1 per 75	1 per 100	$\frac{3}{4}$	1 per 500	$\frac{3}{4}$
		I-3	Prisons <sup>b</sup>	1 per cell	1 per cell	1 per 15	1 per 100	1 service sink
		I-3	Reformatories, detention centers, and correctional centers <sup>b</sup>	1 per 15	1 per 15	1 per 15	1 per 100	1 service sink

NO.	CLASS.	OCC.	DESCRIP.	WATER CLOSETS (URINALS SEE SECTION 419.2)	LAVATORIES	BATHTUBS/SHOWERS	DRINKING FOUNTAIN (SEE SECTION 410.1)	OTHER
-----	--------	------	----------	---	------------	------------------	---------------------------------------	-------

				M	F	M	F			
6	Mercantile (see Sections 403.2, 403.4, 403.4.1 and 403.4.2) <sup>e,f</sup>	M	Retail stores, service stations, shops, salesrooms, markets and shopping centers	1 per 500		1 per 750		-	1 per 1,000	-
7	Residential	R-1	Hotels, motels, boarding houses (transient)	1 per sleeping unit		1 per sleeping unit		1 per sleeping unit	-	1 service sink
		R-2	Dormitories, fraternities, sororities and boarding houses (not transient)	1 per 10		1 per 10		1 per 8	1 per 100	1 service sink
		R-2	Apartment house	1 per dwelling unit		1 per dwelling unit		1 per dwelling unit	-	1 kitchen sink per dwelling unit; 1 automatic clothes washer connection per 20 dwelling units
		R-3	One- and two-family dwellings	1 per dwelling unit		1 per dwelling unit		1 per dwelling unit	-	1 kitchen sink per dwelling unit; 1 automatic clothes washer connection per dwelling unit
		R-4	Residential care/assisted living facilities	1 per 10		1 per 10		1 per 8	1 per 100	1 service sink
8	Storage (see Sections 403.2, 403.4 and 403.4.1)	S-1 S-2	Structures for the storage of goods, warehouses, storehouse and freight depots. Low	1 per 100		1 per 100		See Section 411	1 per 1,000	1 service sink

			and Moderate Hazard.					
--	--	--	----------------------------	--	--	--	--	--

- a. *The fixtures shown are based on one fixture being the minimum required for the number of persons indicated or any fraction of the number of persons indicated. The number of occupants shall be determined by the Florida Building Code, Building.*
- b. *Toilet facilities for employees shall be separate from facilities for inmates or patients.*
- c. *A single-occupant toilet room with one water closet and one lavatory serving not more than two adjacent patient sleeping units shall be permitted where such room is provided with direct access from each patient room and with provisions for privacy.*
- d. *The occupant load for seasonal outdoor seating and entertainment areas shall be included when determining the minimum number of facilities required.*
- e. *In assembly and mercantile occupancies, a unisex toilet room, in accordance with Section 403.7, shall be provided where an aggregate of six or more male and female water closets are required. In buildings of mixed occupancy, only those water closets required for the assembly or mercantile occupancy shall be used to determine the unisex toilet room requirement.*
- f. *In recreational facilities (coliseums, arenas, stadiums, pools, etc., with less than 3,000 seats and coliseums, arenas and stadiums with more 3,000 seats or greater) where separate-sex bathing rooms are provided, a unisex bathing room in accordance with 403.7, shall be provided. Where each separate-sex bathing room has only one shower or bathtub fixture, a unisex bathing room is not required.*

**This reference document consists of information taken from these codes:**

Florida Building Code (FBC-B) - 2007 w/ 2009 supplements

Florida Building Code- Existing Building (FBC-EB) - 2007 Edition (w/ 2009 supplements)

Florida Building Code- Mechanical (FBC-M) - 2007 Edition (w/ 2009 supplements)

Florida Building Code- Fuel-Gas (FBC-FG) - 2007 Edition (w/ 2009 supplements)

Florida Building Code- Plumbing (FBC-P) - 2007 Edition (w/ 2009 supplements)

Florida Fire Prevention Code (FFPC) - 2007 Edition

National Electric Code (NEC) - 2005 Edition